



CHEMISTRY QUESTIONS

MARK SCHEME

This mark scheme is for use in conjunction with
the book *Chemistry Questions for CCEA GCSE*,
ISBN: 978 1 78073 189 6



**COLOURPOINT
EDUCATIONAL**

Colourpoint Educational

An imprint of Colourpoint Creative Ltd

Colourpoint House
Jubilee Business Park
21 Jubilee Road
Newtownards
County Down
Northern Ireland
BT23 4YH

Tel: 028 9182 0505

E-mail: sales@colourpoint.co.uk

Web site: www.colourpoint.co.uk

©2019 Alyn G McFarland and Colourpoint Creative Ltd
All rights reserved.

This material is provided solely for use with the
accompanying textbook. Unauthorised reproduction, in
whole or part, without prior written permission from the
publisher is prohibited.

Publisher's Note: These answers have been written to help students
preparing for the GCSE Chemistry specification from CCEA. While
Colourpoint Educational and the author have taken every care in its
production, we are not able to guarantee that it is completely error-free.
Additionally, while the mark scheme has been written to closely match
the CCEA specification, it is the responsibility of each candidate to
satisfy themselves that they have fully met the requirements of the CCEA
specification prior to sitting an exam set by that body. For this reason,
and because specifications change with time, we strongly advise every
candidate to avail of a qualified teacher and to check the contents of the
most recent specification for themselves prior to the exam. Colourpoint
Creative Ltd therefore cannot be held responsible for any errors or
omissions in this mark scheme or any consequences thereof.

Unit 1:

Structures, Trends, Chemical Reactions,
Quantitative Chemistry and Analysis

Answers

1.1 Atomic Structure

1.

Subatomic particle	Relative charge	Relative mass
electron	-1	$\frac{1}{1840}$
proton	+1	1
neutron	0	1

[1] for each correct row

[3]

Be careful here not to write the relative charge of an electron as 1- or just -; similarly the relative charge of a proton should not be written 1+ or +.

2. (a) Plum pudding Model [1]
 (b) Rutherford [1]
 (c) it has no charge so was more difficult to detect [1]

3. (a) A and E [1]
 (b) A [1]
 (c) Li^+ [1]
 (d) B [1]

4. $\frac{1.87 \times 10^{-10} \text{ m}}{36\,300} = 5.152 \times 10^{-15} \text{ m}$ [1]
 5.15 fm [1] [2]

5. (a) scandium/Sc [1]
 (b) 3+ [1]
 (c) 45 [1]
 (d) 2, 8, 8 [1]
 (e) any two from: $\text{P}^{3-}/\text{S}^{2-}/\text{Cl}^-/\text{K}^+/\text{Ca}^{2+}$ [2]

6.

Atom/ion	Atomic Number	Mass Number	Number of protons	Number of neutrons	Number of electrons	Electronic Configuration
Be	4	9	4	5	4	2, 2
Cl ⁻	17	37	17	20	18	2, 8, 8
K⁺	19	39	19	20	18	2, 8, 8
Ne	10	20	10	10	10	2, 8
Mg ²⁺	12	24	12	12	10	2, 8
N³⁻	7	14	7	7	10	2, 8

Bold text shows the answers – [1] for each correct row.

[6]

7. (a)

- (i) atoms with the same number of protons/same atomic number [1]
but with different numbers of neutrons/different mass numbers [1]

[2]

(ii)

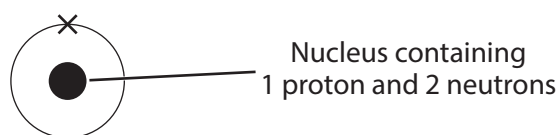

1 electron in shell [1]

nucleus labelled and containing 1 proton and 2 neutrons [1]

[2]

(b) (i) boron

[1]

(ii) 11

[1]

(iii) 2, 3

[1]

(c) (i) $\frac{95 \times 32 + 0.75 \times 33 + 4.25 \times 34}{100}$ [1] = 32.0925 [1] 32.1 [1]

[2] awarded for 32.1 with no working out

[3]

- (ii) same electronic configuration/same number of electrons in the outer shell

[1]

8. (a)

Atom/ion	Identity	Atomic number	Mass number	Number of electrons	Electronic configuration
U	Li ⁺	3	7	2	2
V	Mg	12	24	12	2, 8, 2
W	Na ⁺	11	23	10	2, 8
X	Ca ²⁺	20	40	18	2, 8, 8
Y	P	15	31	15	2, 8, 5
Z	F ⁻	9	19	10	2, 8

[1] for each correct column

[5]

(b) U and W or V and X

[1]

(c) same number of protons and electrons

[1]

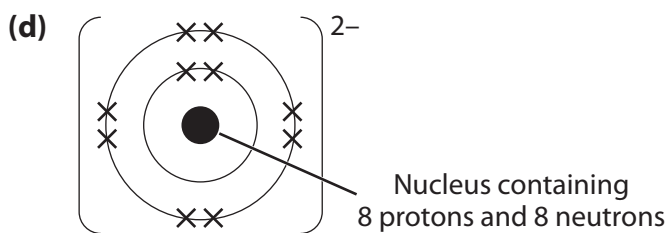

electronic configuration 2, 8 [1]

nucleus labelled and containing 8 protons and 8 neutrons [1]

charge of 2- [1]

[3]

- (c) strong ionic bonding [1]
requires substantial energy to break [1] [2]
- (d) white/crystalline/solid/conducts electricity when molten or dissolved in water [2]
- (e) ionic compounds: lithium iodide
ammonium chloride
magnesium oxide
sodium sulfate
all correct [2]
any additional or one missing [1]
- (f) attraction [1] between the oppositely charged ions [1] [2]
- (g) ionic lattice/giant ionic [1]

3.

Name of compound	Formula of compound	Formula of positive ion	Formula of negative ion
sodium chloride	NaCl	Na ⁺	Cl ⁻
magnesium oxide	MgO	Mg ²⁺	O ²⁻
aluminium fluoride	AlF ₃	Al³⁺	F⁻
potassium nitrate	KNO ₃	K⁺	NO₃⁻
calcium sulfate	CaSO₄	Ca²⁺	SO₄²⁻
copper(II) hydroxide	Cu(OH)₂	Cu²⁺	OH⁻
zinc bromide	ZnBr₂	Zn ²⁺	Br ⁻
iron(III) oxide	Fe₂O₃	Fe³⁺	O²⁻

[1] per row

[8]

4. (a) $\text{CH}_4 + 2\text{O}_2 \rightarrow \text{CO}_2 + 2\text{H}_2\text{O}$
correct formulae of reactants [1]
correct formulae of products [1]
correct balancing [1] [3]

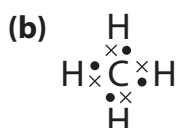

any one of the four lone pairs labelled

[1]

(ii) covalent

[1]

(iii) van der Waals' forces

[1]

(c) ionic [1]

(d) ions can move [1] and carry charge [1] [2]

The most common error in (d) is to state that “delocalised electrons can move and carry charge” which is not correct. Remember that for metals and graphite it is delocalised electrons which can move and carry charge and for molten ionic compounds, ionic compounds in solution and acids, it is ions.

(e) covalent [1]

(f) weak van der Waals' forces between the molecules [1]
require little energy to break [1] [2]

(g) molecular covalent/simple covalent [1]

(h) high melting point/high boiling point [1]
does not conduct electricity [1] [2]

7. (a) (i)

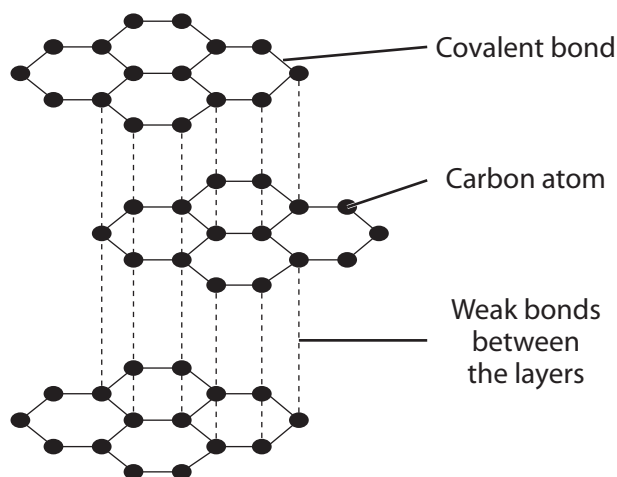

a layer showing a minimum of 3 tessellated hexagons [1]

a minimum of 2 layers [1]

covalent bond between carbon atoms [1]

weak bonds between the layers [1]

[4]

(ii) delocalised electrons can move [1] and carry charge [1] [2]

(iii) high melting point/high boiling point [1]

(b) (i) diamond [1]

(ii) carbon atom [1]

(iii) covalent bond [1]

(iv) different forms of the same element [1]
in the same physical state [1] [2]

(v) lubricant/electrodes/pencils [1]

8. (a)

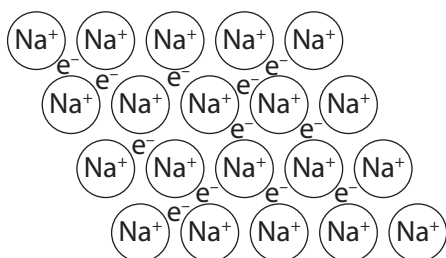

layers/lattice [1]
of positive ions/cations [1]
(in a sea of) delocalised electrons [1] [3]

(b) delocalised electrons can move [1]
(delocalised electrons) can carry charge [1]
magnesium has more outer shell electrons/more delocalised electrons than sodium [1] [3]

(c) (i) mixture of two or more elements [1]
at least one of which is a metal [1]
and the resulting mixture has metallic properties [1] [3]

(ii) different size atoms [1]
distort the metallic structure [1] [2]

(iii) low density [1]

9.

Carat rating	Percentage of pure gold
24	100 [1]
18 [1]	75
11	45.8/46 [1]

[3]

1.5 Symbols, Formulae and Equations

1. (a) oxygen and nitrogen [1]
 (b) methane and magnesium oxide and ammonia and water [1]
 (c) copper(II) hydroxide = $\text{Cu}(\text{OH})_2$ [1]
 sodium sulfate = Na_2SO_4 [1]
 methane = CH_4 [1]
 ammonia = NH_3 [1] [4]
 (d) $2\text{Mg} + \text{O}_2 \rightarrow 2\text{MgO}$ [3]
2. (a) KBr [1]
 (b) CaO [1]
 (c) MgCl_2 [1]
 (d) $\text{Fe}(\text{OH})_2$ [1]
 (e) $\text{Al}_2(\text{SO}_4)_3$ [1]
 (f) $\text{Cr}(\text{NO}_3)_3$ [1]
 (g) $(\text{NH}_4)_2\text{SO}_4$ [1]
3. (a) zinc oxide [1]
 (b) silver nitrate [1]
 (c) potassium carbonate [1]
 (d) iron(II) nitrate [1]
 (e) calcium hydrogencarbonate [1]
 (f) copper(II) sulfate [1]
 (g) aluminium hydroxide [1]
4. (a) $\text{Fe} + \text{S} \rightarrow \text{FeS}$ [2]
 (b) $\text{Zn} + \text{H}_2\text{O} \rightarrow \text{ZnO} + \text{H}_2$ [2]
 (c) $2\text{Cu} + \text{O}_2 \rightarrow 2\text{CuO}$ [3]
 (d) $4\text{Al} + 3\text{O}_2 \rightarrow 2\text{Al}_2\text{O}_3$ [3]
 (e) $\text{H}_2 + \text{Cl}_2 \rightarrow 2\text{HCl}$ [3]
 (f) $\text{Al}_2\text{O}_3 + 6\text{HCl} \rightarrow 2\text{AlCl}_3 + 3\text{H}_2\text{O}$ [3]
 (g) $4\text{Li} + \text{O}_2 \rightarrow 2\text{Li}_2\text{O}$ [3]
 (h) $2\text{K} + 2\text{H}_2\text{O} \rightarrow 2\text{KOH} + \text{H}_2$ [3]

5. (a) $\text{NaOH} + \text{HCl} \rightarrow \text{NaCl} + \text{H}_2\text{O}$ [2]
 (i) $\text{Cu}(\text{OH})_2 + 2\text{HNO}_3 \rightarrow \text{Cu}(\text{NO}_3)_2 + 2\text{H}_2\text{O}$ [3]
 (j) $2\text{KHCO}_3 + \text{H}_2\text{SO}_4 \rightarrow \text{K}_2\text{SO}_4 + 2\text{CO}_2 + 2\text{H}_2\text{O}$ [3]
 (k) $\text{NH}_3 + \text{HCl} \rightarrow \text{NH}_4\text{Cl}$ [2]
 (l) $2\text{Al}(\text{OH})_3 + 3\text{H}_2\text{SO}_4 \rightarrow \text{Al}_2(\text{SO}_4)_3 + 6\text{H}_2\text{O}$ [3]
 (m) $\text{Mg} + 2\text{HNO}_3 \rightarrow \text{Mg}(\text{NO}_3)_2 + \text{H}_2$ [3]
 (n) $(\text{NH}_4)_2\text{SO}_4 + 2\text{NaOH} \rightarrow \text{Na}_2\text{SO}_4 + 2\text{NH}_3 + 2\text{H}_2\text{O}$ [3]
6. (a) $\text{Ca}(\text{OH})_2(\text{aq}) + \text{CO}_2(\text{g}) \rightarrow \text{CaCO}_3(\text{s}) + \text{H}_2\text{O}(\text{l})$ [3]
 (b) (i) $\text{AgNO}_3(\text{aq}) + \text{LiBr}(\text{aq}) \rightarrow \text{AgBr}(\text{s}) + \text{LiNO}_3(\text{aq})$ [3]
 (ii) $\text{Ag}^+(\text{aq}) + \text{Br}^-(\text{aq}) \rightarrow \text{AgBr}(\text{s})$ [3]
7. (a) $2\text{Ca} + \text{O}_2 \rightarrow 2\text{CaO}$ [3]
 (b) $\text{Zn} + 2\text{HCl} \rightarrow \text{ZnCl}_2 + \text{H}_2$ [3]
 (c) $\text{CuO} + \text{H}_2\text{SO}_4 \rightarrow \text{CuSO}_4 + \text{H}_2\text{O}$ [2]
 (d) $\text{Li}_2\text{CO}_3 + \text{H}_2\text{SO}_4 \rightarrow \text{Li}_2\text{SO}_4 + \text{CO}_2 + \text{H}_2\text{O}$ [2]
 (e) $2\text{NH}_3 + \text{H}_2\text{SO}_4 \rightarrow (\text{NH}_4)_2\text{SO}_4$ [3]
 (f) $\text{Fe}(\text{OH})_3 + 3\text{HNO}_3 \rightarrow \text{Fe}(\text{NO}_3)_3 + 3\text{H}_2\text{O}$ [3]
 (g) $\text{NaHCO}_3 + \text{HCl} \rightarrow \text{NaCl} + \text{CO}_2 + \text{H}_2\text{O}$ [2]
 (h) $\text{Ca} + 2\text{H}_2\text{O} \rightarrow \text{Ca}(\text{OH})_2 + \text{H}_2$ [3]
 (i) $\text{Mg} + \text{H}_2\text{O} \rightarrow \text{MgO} + \text{H}_2$ [2]
8. (a) sulfate/ SO_4^{2-} [1]
 (b) $\text{Zn} + \text{Cu}^{2+} \rightarrow \text{Zn}^{2+} + \text{Cu}$ [2]
 (c) $\text{Zn} \rightarrow \text{Zn}^{2+} + 2\text{e}^-$ [3]
 $\text{Cu}^{2+} + 2\text{e}^- \rightarrow \text{Cu}$ [3] [6]

In question 8, the sulfate ion is not changed from left to right in the reaction so it is a spectator ion. Spectator ions are not included in the ionic equation. The half equations are determined from the ionic equation. Zn goes to Zn^{2+} and to do this Zn loses 2e^- . The lost 2e^- are most often written on the right as $+2\text{e}^-$ but $\text{Zn} - 2\text{e}^- \rightarrow \text{Zn}^{2+}$ is also acceptable. The Cu^{2+} become Cu and to do this 2e^- must be gained on the left so $+2\text{e}^-$ is added on the left. This links with redox in unit 2 which describes oxidation and reduction in terms of loss and gain of electrons.

4. (a) a substance which consists of only one type of atom/a substance which cannot be broken down into anything simpler by chemical means. [1]

(b) any three from:

- elements were arranged in order of atomic mass/atomic weight but they are in order of atomic number in the modern table
- left gaps for undiscovered elements but no gaps in modern table
- less elements in Mendeleev's Table and more in the modern table
- no block of transition metals/no block of lanthanides or actinides but they are present in the modern table
- no noble gases but they are present in the modern table [3]

(c) any two from:

malleable/ductile/conduct electricity/conduct heat/sonorous [2]

(d)

Group of the Periodic Table	Name of group
1	alkali metals [1]
2	alkaline earth metals [1]
7	halogens [1]

[3]

(e) same number of electrons in the outer shell

[1]

5. (a) stored under oil [1]

prevent it reacting with oxygen and water [1] [2]

(b) circles round:

floats

melts to form a silvery ball

disappears

colourless solution formed

heat released

each missing or additional [-1]

[2]

(c) $2\text{Na} + 2\text{H}_2\text{O} \rightarrow 2\text{NaOH} + \text{H}_2$

correct formulae of reactants [1]

correct formulae of products [1]

correct balancing [1]

[3]

(d) (i) $\text{Na} \rightarrow \text{Na}^+ + \text{e}^-$

Na on left of arrow and Na^+ on right [1]

+ e^- on right (or - e^- on left) [1]

[2]

[2]

(ii) 2, 8

[1]

- (e) potassium more reactive than sodium [1]
 outer electron is further from the nucleus/more shielding in potassium [1]
 outer electron is less attracted to the nucleus/lost more readily in potassium [1] [3]
6. (a) shiny [1] to dull [1] [2]
 (b) prevent reaction being too vigorous [1]
 (c) remove oil [1]
 (d) prevent excess heat/control the reaction [1]
 (e) prevent exploding potassium/corrosive solution hitting observers [1]
 (f) potassium hydroxide [1] hydrogen [1] [2]
 (g) less dense as it floats on water [1]
7. (a) fluorine = yellow gas [1]
 chlorine = green/yellow-green gas [1]
 bromine = red-brown liquid [1]
 iodine = dark grey/grey-black solid [1] [4]
- (b) (i) $\text{Cl}_2 + 2\text{KI} \rightarrow 2\text{KCl} + \text{I}_2$
 correct formulae of reactants [1]
 correct formulae of products [1]
 correct balancing [1] [3]
- (ii) displacement [1]
- (iii) colourless [1] to yellow/brown [1] [2]
- (iv) $\text{Cl}_2 + 2\text{I}^- \rightarrow 2\text{Cl}^- + \text{I}_2$
 correct formulae of reactants [1]
 correct formulae of products [1]
 correct balancing [1] [3]
- (v) $\text{Cl}_2 + 2\text{e}^- \rightarrow 2\text{Cl}^-$ [3]
 Cl_2 on left of arrow and Cl^- on right [1]
 $+ \text{e}^-$ on left [1]
 correct balancing [1]
- $2\text{I}^- \rightarrow \text{I}_2 + 2\text{e}^-$ [3]
 I^- on left of arrow and I_2 on right [1]
 $+ \text{e}^-$ on right (or $- \text{e}^-$ on left) [1]
 correct balancing [1] [6]

The potassium ion is the spectator ion in this reaction so it is left out of the ionic equation. The half equations are again determined from the ionic equation. Cl_2 goes to Cl^- and I^- goes to I_2 . The balancing numbers are required as there are two Cl atoms in Cl_2 so it forms 2Cl^- . Also, 2I^- are required to form I_2 .

8. (a) bromine water is yellow/orange/brown [1]
solution produced/iodine solution is brown [1] [2]
- (b) $\text{Br}_2 + 2\text{NaI} \rightarrow 2\text{NaBr} + \text{I}_2$
correct formulae of reactants [1]
correct formulae of products [1]
correct balancing [1] [3]
- (c) outer shell (electrons) closer to the nucleus in bromine [1]
gained electron is more strongly attracted to the nucleus [1] [2]
9. (a) (i) damp universal indicator paper [1]
changed to red then bleaches white [1] [2]
- (ii) $2\text{Cl}^- \rightarrow \text{Cl}_2 + 2\text{e}^-$
 Cl^- on left of arrow and Cl_2 on right [1]
 $+ \text{e}^-$ on right (or $- \text{e}^-$ on left) [1]
correct balancing [1] [3]
- (iii) outer shell electrons closer to nucleus in chlorine [1]
more strongly attracted to the nucleus [1] [2]
- (d) (i) sublimation [1]
- (ii) dark grey/grey black [2] solid changes to a purple [1] gas [2]

10. Indicative content:

- $\text{Cl}_2 + 2\text{NaBr} \rightarrow 2\text{NaCl} + \text{Br}_2$ [3]
- colourless solution [1] changes to yellow/orange/brown [1]
- $\text{Cl}_2 + 2\text{NaI} \rightarrow 2\text{NaCl} + \text{I}_2$ [3]
- colourless solution [1] changes to yellow/brown [1]
- chlorine is more reactive than bromine and iodine [1]

Band	Response	Mark
A	Candidates must use appropriate specialist terms to explain fully the displacement reactions and reactivity of the halogens including balanced symbol equations [9 – 11 indicative content points]. Relevant material is organised with a high degree of clarity and coherence. They must use excellent spelling, punctuation and grammar and the form and style are of a very high standard.	[5]–[6]
B	Candidates must use appropriate specialist terms to explain fully the displacement reactions and reactivity of the halogens including balanced symbol equations [3 – 8 indicative content points]. Relevant material is organised with some clarity and coherence. They use good spelling, punctuation and grammar and the form and style are of a satisfactory standard.	[3]–[4]
C	Candidates describe briefly the displacement reactions and reactivity of the halogens [at least 2 indicative content points]. The organisation of material may lack clarity and coherence. They use limited spelling, punctuation and grammar and they have limited use of specialist terms. The form and style are of limited standard	[1]–[2]
D	A response not worthy of credit	[0]

This is the first QWC question in the question book and it is marked using a banded mark scheme as shown above. The examiner will mark the indicative content in your answer to decide which band your answer will be in. If you achieve 8 points, you will be in Band B which means if your answer is well written with good spelling, punctuation and grammar (SPG) you will be given the top mark in Band B which is 4. If you had achieved 9, 10 or 11 indicative points, your answer would be in Band A and if SPG is good, you will achieve 6 marks. Write these answers using capital letters, spell everything correctly and use correct punctuation.

11. (a) transition metals have higher melting points than Group I metals.

[1]

(b)

Substance	Colour
potassium iodide solution	colourless [1]
solid copper(II) oxide	black [1]
copper(II) sulfate solution	blue [1]
solid sodium bromide	white [1]
solid copper(II) carbonate	green [1]
hydrated copper(II) sulfate	blue [1]

[6]

1.7 Quantitative Chemistry

Basics of Quantitative Chemistry

1. The relative atomic mass is the mass of an **atom** [1] compared with that of the **carbon-12** [1] isotope, which has a mass of exactly **12** [1]. The relative atomic mass is **weighted** [1] mean of the **mass numbers** [1].

2.

Name of compound	Formula of compound	Relative formula mass
water	H ₂ O	18
calcium bromide	CaBr₂	200
aluminium nitrate	Al(NO₃)₃	213
potassium nitrate	KNO₃	101
iron(III) oxide	Fe ₂ O ₃	160
chromium(III) sulfate	Cr₂(SO₄)₃	392
ammonium carbonate	(NH₄)₂CO₃	96
copper(II) carbonate	CuCO₃	124
magnesium hydroxide	Mg(OH)₂	58
zinc sulphate – 7 – water	ZnSO₄.7H₂O	287
silver(I) nitrate	AgNO₃	170
sodium carbonate	Na₂CO₃	106

[1] per correct row

[12]

Interchanging mass and moles

3. (a) $\frac{2.7}{27} = 0.1$ [1]

(b) $\frac{32.1}{53.5} = 0.6$ [1]

(c) $\frac{144}{180} = 0.8$ [1]

(d) $\frac{17.76}{74} = 0.24$ [1]

(e) $\frac{6.48}{162} = 0.04$ [1]

4. (a) $0.075 \times 164 = 12.3 \text{ g}$ [1]
 (b) $0.04 \times 238 = 9.52 \text{ g}$ [1]
 (c) $1.75 \times 80 = 140 \text{ g}$ [1]
 (d) $0.5 \times 102 = 51 \text{ g}$ [1]
 (e) $0.04 \times 250 = 10 \text{ g}$ [1]
5. (a) $\frac{4200 [1]}{84} = 50 [1]$ [2]
 (b) $120 \times 85 = 10200 \text{ g} [1]$ $10.2 \text{ kg} [1]$ [2]
 (c) $\frac{11\,200\,000 [1]}{160} = 70\,000 [1]$ [2]
 (d) $40\,000 \times 84 = 3\,360\,000 \text{ g} [1]$ $3.36 \text{ tonnes} [1]$ [2]
 (e) $\frac{19\,500 [1]}{78} = 250 [1]$ [2]
 (f) $200 \times 286 = 57\,200 \text{ g} [1]$ $57.2 \text{ kg} [1]$ [2]

Reacting mass calculations

6. moles of Li = $\frac{1.75}{7} = 0.25 [1]$
 moles of Li_2O formed = $\frac{0.25}{2} = 0.125 [1]$ (4:2 ratio of Li: Li_2O)
 mass of Li_2O formed = $0.125 \times 30 = 3.75 \text{ g} [1]$ [3]
7. moles of $\text{AgNO}_3 = \frac{4.76}{170} = 0.028 [1]$
 moles of Ag formed = $0.028 [1]$ (2:2 ratio of AgNO_3 :Ag)
 mass of Ag formed = $0.028 \times 108 = 3.024 \text{ g} [1]$ [3]
8. moles of $\text{Ca}_3\text{N}_2 = \frac{8.14}{148} = 0.055 [1]$
 moles of Ca(OH)_2 formed = $0.055 \times 3 = 0.165 [1]$ (1:3 ratio of Ca_3N_2 : Ca(OH)_2)
 mass of Ca(OH)_2 formed = $0.165 \times 74 = 12.21 \text{ g} [1]$ [3]
9. moles of Fe = $\frac{560\,000 [1]}{56} = 10\,000 [1]$
 moles of Fe_2O_3 formed = $\frac{10\,000}{2} = 5000 [1]$ (1:2 ratio of Fe_2O_3 :Fe)
 mass of Fe_2O_3 formed = $5000 \times 160 = 800\,000 \text{ g} = 800 \text{ kg} [1]$ [4]

$$10. \text{ moles of Na}_2\text{S}_2\text{O}_3 = \frac{711}{158} = 4.5 \text{ [1]}$$

$$\text{moles of Na}_2\text{SO}_4 \text{ formed} = \frac{4.5}{4} \times 3 = 3.375 \text{ [1] (4:3 ratio of Na}_2\text{S}_2\text{O}_3\text{:Na}_2\text{SO}_4\text{)}$$

$$\text{mass of Na}_2\text{SO}_4 \text{ formed} = 3.375 \times 142 = 479.25 \text{ g [1] [3]}$$

$$11. \text{ moles of NaHCO}_3 = \frac{6.72}{84} = 0.08 \text{ [1]}$$

$$\text{moles of Na}_2\text{CO}_3 \text{ formed} = \frac{0.08}{2} = 0.04 \text{ [1]}$$

$$\text{mass of Na}_2\text{CO}_3 \text{ formed} = 0.04 \times 106 = 4.24 \text{ g [1] [3]}$$

$$12. \text{ moles of Al}_2\text{O}_3 = \frac{4.59}{102} = 0.045 \text{ [1]}$$

$$\text{moles of Al required} = 0.045 \times 2 = 0.09 \text{ [1]}$$

$$\text{mass of Al required} = 0.09 \times 27 = 2.43 \text{ g [1] [3]}$$

This is a slightly different question as you are given the mass of a product and asked to find the mass of a reactant but the same method applies, calculate moles using M_r , calculate moles using ratio and calculate mass using M_r .

$$13. \text{ moles of Fe}_2\text{O}_3 = \frac{432}{160} = 2.7 \text{ [1]}$$

$$\text{moles of Fe(OH)}_3 = 2.7 \times 2 = 5.4 \text{ [1]}$$

$$\text{mass of Fe(OH)}_3 = 5.4 \times 107 = 577.8 \text{ g [1] [3]}$$

$$14. \text{ moles of Fe} = \frac{2.24}{56} = 0.04 \text{ [1]}$$

$$\text{moles of Fe}_3\text{O}_4 = \frac{0.04}{3} = 0.0133 \text{ [1]}$$

$$\text{mass of Fe}_3\text{O}_4 = 0.0133 \times 232 = 3.09 \text{ g [1] [3]}$$

This calculation produces 0.0133333333 etc moles of Fe_3O_4 . You can round this to 3 or 4 significant figures during your calculation. 0.0133 is rounded to 3 significant figures and is used to calculate the final answer. The number in your calculator will give the same answer. Do not round a number such as this number of moles to fewer than 3 significant figures.

15. moles of $\text{Pb}(\text{NO}_3)_2 = \frac{3.31}{331} = 0.01$ [1]

moles of PbO formed = 0.01 [1] (2:2 ratio of $\text{Pb}(\text{NO}_3)_2$: PbO)

mass of PbO formed = $0.01 \times 223 = 2.23$ g [1]

loss in mass = $3.31 - 2.23 = 1.08$ g [1]

[4]

For question 7, you could also calculate the total mass of gases NO_2 and O_2 formed as this is what causes the loss in mass.

moles of $\text{NO}_2 = 0.01 \times 2 = 0.02$

mass of $\text{NO}_2 = 0.02 \times 46 = 0.92$ g

moles of $\text{O}_2 = 0.01 \div 2 = 0.005$

mass of $\text{O}_2 = 0.005 \times 32 = 0.16$ g

total mass of gases = $0.92 + 0.16 = 1.08$ g

Limiting reactant calculations

16. zinc is the limiting reactant [1]

Zn is limiting reactant as 0.12 mol of Zn would require 0.24 mol of HCl but 0.25 mol of HCl are present so HCl is in excess and Zn is the limiting reactant.

moles of zinc chloride formed = 0.12 [1]

mass of zinc chloride formed = $0.12 \times 136 = 16.32$ g [1]

[3]

You could work out the moles of HCl left over. $0.25 - 0.24 = 0.01$ mol of HCl left over.

17. oxygen is the limiting reactant [1]

O_2 is the limiting reactant as 1.5 mol of SO_2 would require 0.75 mol of O_2 but only 0.6 mol of O_2 present.

moles of SO_3 formed = $0.6 \times 2 = 1.2$ [1]

mass of SO_3 formed = $1.2 \times 80 = 96$ g [1]

[3]

You could work out the moles of SO_2 left over. 0.6 mol of O_2 react with 1.2 mol of SO_2 so $1.5 - 1.2 = 0.3$ mol of SO_2 left over.

18. (a) moles of $(\text{NH}_4)_2\text{SO}_4 = \frac{2.64}{132} = 0.02$ [1]

(b) moles of $\text{NaOH} = \frac{1.40}{40} = 0.035$ [1]

[1]

(c) NaOH is the limiting reactant [1]

[1]

Using the ratio of 1:2 for $(\text{NH}_4)_2\text{SO}_4$:NaOH from the equation, 0.02 mol of $(\text{NH}_4)_2\text{SO}_4$ would require 0.04 mol of NaOH to react completely. There are only 0.035 mol of NaOH so it is the limiting reactant. The limiting reactant moles are used to calculate the moles of the products formed.

(d) moles of $\text{Na}_2\text{SO}_4 = \frac{0.035}{2} = 0.0175$ [1]

(e) mass of $\text{Na}_2\text{SO}_4 = 0.0175 \times 142 = 2.485 \text{ g}$ [1]

19. (a) moles of $\text{KO}_2 = \frac{3500 [1]}{71} = 50 [1]$ [2]

(b) moles of $\text{CO}_2 = \frac{968}{44} = 22$ [1]

(c) carbon dioxide is the limiting reactant [1]

50 mol of KO_2 reacts with 25 mol of CO_2 but only 22 mol of CO_2 present so CO_2 is the limiting reactant.

(d) moles of oxygen formed = $\frac{22}{2} \times 3 = 33$ [1]

(e) mass of oxygen = $33 \times 32 = 1056 \text{ g} [1]$ $1.056 \text{ kg} [1]$ [2]

20. (a) moles of $\text{Al}_2\text{O}_3 = \frac{6.12 [1]}{102} = 0.06 [1]$

moles of $\text{Ca} = \frac{4.80 [1]}{40} = 0.12 [1]$

0.06 moles of Al_2O_3 requires 0.18 moles of Ca but only 0.12 of Ca present [1] [3]

(b) moles of Al formed = $\frac{0.12}{3} \times 2 = 0.08 [1]$

mass of $\text{Al} = 0.08 \times 27 = 2.16 \text{ g} [1]$ [2]

(c) moles of Al_2O_3 used = $\frac{0.12}{3} = 0.04 [1]$

moles of Al_2O_3 left over = $0.06 - 0.02 = 0.02 [1]$

mass of Al_2O_3 left over = $0.02 \times 102 = 2.04 \text{ g} [1]$ [3]

21. (a) moles of $\text{Li} = \frac{2.1}{7} = 0.3 [1]$

moles of $\text{S} = \frac{4.0}{32} = 0.125 [1]$

sulfur is the limiting reactant [1]

0.3 mol of Li reacts with 0.15 mol of S but only 0.125 mol of S present so S is the limiting reactant

moles of Li_2S formed = $0.125 \times 2 = 0.25 [1]$

mass of Li_2S formed = $0.25 \times 46 = 11.5 \text{ g} [1]$ [5]

(b) moles of Li used = $0.125 \times 2 = 0.25 [1]$

moles of Li left over = $0.3 - 0.25 = 0.05 [1]$

mass of Li left over = $0.05 \times 7 = 0.35 \text{ g} [1]$ [3]

$$22. (a) \text{ moles of NH}_3 = \frac{13.6}{17} = 0.8 \text{ [1]}$$

$$\text{moles of O}_2 = \frac{20.0}{32} = 0.625 \text{ [1]}$$

NH₃ is the limiting reactant [1]

0.8 mol of NH₃ reacts with 0.6 mol of O₂ but as there are 0.625 mol of O₂ present, the O₂ is in excess and the NH₃ is the limiting reactant.

$$\text{moles of N}_2 \text{ formed} = \frac{0.8}{2} = 0.4 \text{ [1]}$$

$$\text{mass of N}_2 \text{ formed} = 0.4 \times 28 = 11.2 \text{ g [1]} \quad [5]$$

$$(b) \text{ moles of O}_2 \text{ used} = \frac{0.8}{4} \times 3 = 0.6 \text{ [1]}$$

$$\text{moles of O}_2 \text{ left over} = 0.625 - 0.6 = 0.025 \text{ [1]}$$

$$\text{mass of O}_2 \text{ left over} = 0.025 \times 32 = 0.8 \text{ g [1]} \quad [3]$$

Percentage yield calculations

$$23. (a) \text{ moles of CaCO}_3 \text{ used} = \frac{14.5}{100} = 0.145 \text{ [1]}$$

$$\text{moles of Ca(NO}_3)_2 \text{ formed} = 0.145 \text{ [1]} \text{ (1:1 ratio of CaCO}_3\text{:Ca(NO}_3)_2\text{)}$$

$$\text{mass of Ca(NO}_3)_2 \text{ formed} = 0.145 \times 164 = 23.78 \text{ g [1]} \quad [3]$$

This is a reacting mass calculation as it is the maximum mass of calcium nitrate which could be obtained from the calcium carbonate.

$$(b) \text{ percentage yield} = \frac{\text{actual yield}}{\text{theoretical yield}} \times 100 = \frac{20.8}{23.78} \times 100 \text{ [1]} = 87.5 \% \text{ [1]} \quad [2]$$

Round your answer to 1 decimal place. The answer is 87.46846089 and when rounded to 1 decimal place this is 87.5. The answer to 2 decimal places is 87.47 %.

$$24.(a) \text{ moles of NH}_3 \text{ used} = \frac{6800 \text{ [1]}}{17} = 400 \text{ [1]}$$

$$\text{moles of NH}_4\text{Cl formed} = \frac{400}{8} \times 6 = 300 \text{ [1]}$$

$$\text{mass of NH}_4\text{Cl formed} = 300 \times 53.5 = 16\,050 \text{ g} = 16.05 \text{ kg [1]}$$

$$(b) \text{ percentage yield} = \frac{\text{actual yield}}{\text{theoretical yield}} \times 100 = \frac{7.0}{16.05} \times 100 \text{ [1]} = 43.6 \% \text{ [1]} \quad [2]$$

25. (a) $V_2O_5 + 5Ca \rightarrow 5CaO + 2V$
 correct formulae of reactants [1]
 correct formulae of products [1]
 correct balancing [1] [3]

(b) (i) moles of $V_2O_5 = \frac{8\,190\,000 [1]}{182} = 45\,000 [1]$
 moles of V formed = $45\,000 \times 2 = 90\,000 [1]$
 mass of V formed = $90\,000 \times 51 = 4\,590\,000 \text{ g} = 4.59 \text{ tonnes} [1]$ [4]

(ii) percentage yield = $\frac{\text{actual yield}}{\text{theoretical yield}} \times 100 = \frac{3.80}{4.59} \times 100 [1] = 82.79\% [1]$ [2]

(iii) any from:
 incomplete reaction
 side reactions/different products formed [1]

26. (a) moles of $CuCO_3 = \frac{12.4}{124} = 0.1$ [1]

(b) moles of $CuSO_4(aq) = 0.1$ (1:1 ratio of $CuCO_3(s) : CuSO_4(aq)$) [1]

(c) $0.1 \times 250 = 25.0 \text{ g}$ [1]

(d) percentage yield = $\frac{\text{actual yield}}{\text{theoretical yield}} \times 100 = \frac{20.8}{25.0} \times 100 [1] = 83.2\% [1]$ [2]

(e) loss by mechanical transfer [1]
 not all crystallised [1] [2]

27. (a) moles of NaOH = $\frac{12.0}{40} = 0.3$ [1]

(b) moles of $FeCl_3 = \frac{19.5}{162.5} = 0.12$ [1]

(c) NaOH is limiting reactant [1]

0.3 mol of NaOH would require 0.1 mol of $FeCl_3$. However, there are 0.12 mol of $FeCl_3$ so it is in excess and NaOH is the limiting reactant.

(d) moles of $Fe(OH)_3 = \frac{0.3}{3} = 0.1$ [1]

(e) mass of $Fe(OH)_3 = 0.1 \times 107 = 10.7 \text{ g}$ [1]

(f) percentage yield = $\frac{\text{actual yield}}{\text{theoretical yield}} \times 100 = \frac{7.22}{10.7} \times 100 [1] = 67.5\% [1]$ [2]

Determining formulae of compounds

28. (a) C_2H_5 [1]

(b) C_6H_{14} is a molecular formula as C_3H_7 would be the empirical formula [1]

29.

Name	Empirical formula	Relative formula mass (M_r)	Molecular formula
ammonia	NH_3	17	NH_3 [1]
ethene	CH_2	28	C_2H_4 [1]
benzene	CH	78	C_6H_6 [1]
decane	C_5H_{11}	142	$C_{10}H_{22}$ [1]

[4]

The molecular formula may be the same as the empirical formula or it may be a multiple of it. The relative atomic mass is the clue here as for ethene CH_2 gives a mass of 14 but the relative atomic mass is 28 so the formula must be $2 \times CH_2$ which is C_2H_4 . The others follow this example.

30.

	Cr	O
mass (g)	68.4	31.6
moles	$\frac{68.4}{52} = 1.315$ [1]	$\frac{31.6}{16} = 1.975$ [1]
ratio	$\frac{1.315}{1.315} = 1$	$\frac{1.975}{1.315} = 1.5$
formula	Cr_2O_3 [1]	

This is the first example of this kind for finding the empirical formula of a compounds from percentage data.

- Assuming 100 g of the compound, the percentage of chromium is taken as the mass of chromium in grams so it is 68.4 g.
- The compound only contains two elements so $100 - 68.4 = 31.6$ g is the mass of oxygen.
- The moles of the atoms of the elements are calculated by dividing by the relative atomic mass. Don't be tempted to use 32 for oxygen as this is for O_2 and you want to know how many O are present not how many O_2 .
- The lowest number of moles (1.315) is then divided into all the others.
- As 1 and 1.5 are obtained as a ratio, these are multiplied by 2 to give a whole number ratio of 2:3 so the formula is Cr_2O_3 .

31.

	Fe	S
mass (g)	46.7	53.3
moles	$\frac{46.7}{56} = 0.834$ [1]	$\frac{53.3}{32} = 1.666$ [1]
ratio	$\frac{0.834}{0.834} = 1$	$\frac{1.666}{0.834} = 2$
formula	FeS_2 [1]	

As the percentages are often given to only 1 decimal place the ratio may not work out to be exactly 1:2. In this case it is 1:1.9976. The second figure is so close to 2 that it can be taken as 2. Be careful with 1.34 for example as a ratio number as this is probably 1.33 and so all the ratio numbers should be multiplied by 3 to obtain whole numbers.

32.

	Fe	Cl
mass (g)	34.5	65.5
moles	$\frac{34.5}{56} = 0.616$ [1]	$\frac{65.5}{35.5} = 1.845$ [1]
ratio	$\frac{0.616}{0.616} = 1$	$\frac{1.845}{0.616} = 3$
formula	FeCl_3 [1]	

33.

	S	F
mass (g)	21.9	78.1
moles	$\frac{21.9}{32} = 0.684$ [1]	$\frac{78.1}{19} = 4.111$ [1]
ratio	$\frac{0.684}{0.684} = 1$	$\frac{4.111}{0.684} = 6$
formula	SF_6 [1]	

34.

	Pb	O
mass (g)	$13.70 - 1.28 = 12.42$ [1]	1.28
moles	$\frac{12.42}{207} = 0.06$ [1]	$\frac{1.28}{16} = 0.08$ [1]
ratio	$\frac{0.06}{0.06} = 1$	$\frac{0.08}{0.06} = 1.33333$
formula	Pb_3O_4 [1]	

Note that a subtraction must be carried out as the 13.70 g is the total mass of the compound so the mass of lead is calculated by subtracting the mass of oxygen from the total mass of the compound.

35.

	N	O
mass (g)	0.14	0.40
moles	$\frac{0.14}{14} = 0.01$ [1]	$\frac{0.40}{16} = 0.025$ [1]
ratio	$\frac{0.01}{0.01} = 1$	$\frac{0.025}{0.01} = 2.5$
formula	N_2O_5 [1]	

36.

	Cl	O
mass (g)	2.84 [1]	$7.32 - 2.84 = 4.48$ [1]
moles	$\frac{2.84}{35.5} = 0.08$ [1]	$\frac{4.48}{16} = 0.28$ [1]
ratio	$\frac{0.08}{0.08} = 1$	$\frac{0.028}{0.08} = 3.5$
formula	Cl_2O_7 [1]	

37.

	P	S
mass (g)	3.1	4.8
moles	$\frac{3.1}{31} = 0.1$ [1]	$\frac{4.8}{32} = 0.15$ [1]
ratio	$\frac{0.1}{0.1} = 1$	$\frac{0.15}{0.1} = 1.5$
formula	P_2S_3 [1]	

38. (a) $17.52 - 14.22 = 3.3$ g [1]
- (b) $\frac{3.3}{55} = 0.06$ [1]
- (c) $18.80 - 17.52 = 1.28$ g [1]
- (d) $\frac{1.28}{16} = 0.08$ [1]
- (e) $0.06:0.08 = 3:4$ so Mn_3O_4 [1]

This is another common type of question where you would have to extract the information from the mass data given. Similar questions will be seen where a sample of a hydrated salt is heated to remove all of the water of crystallisation. This can then be used to determine the degree of hydration of the hydrated salt. The process of heating and weighing and repeating until the same mass is obtained is called heating to constant mass.

39. (a) prevent loss of the oxide of titanium/product [1]
- (b) allow more air/oxygen in [1]
- (c) heat to constant mass [1]
- (d) mass of Ti = $14.97 - 14.25 = 0.72$ g [1]

$$\text{moles of Ti} = \frac{0.72}{48} = 0.015 \text{ [1]}$$

$$\text{mass of O} = 15.45 - 14.97 = 0.48 \text{ g [1]}$$

$$\text{moles of O} = \frac{0.48}{16} = 0.03 \text{ [1]}$$

$$0.015:0.03 = 1:2 \text{ so formula is } \text{TiO}_2 \text{ [1] [5]}$$

40.

	Na	Cr	O
mass (g)	28.4	32.1	39.5
moles	$\frac{28.4}{23} = 1.235$ [1]	$\frac{32.1}{52} = 0.617$ [1]	$\frac{39.5}{16} = 2.469$ [1]
ratio	$\frac{1.235}{0.617} = 2$	$\frac{0.617}{0.617} = 1$	$\frac{2.469}{0.617} = 4$
formula	Na_2CrO_4 [1]		

[4]

41.

	C	H	N	O
mass (g)	1.20	0.22	0.28	0.64
moles	$\frac{1.20}{12} = 0.1$ [1]	$\frac{0.22}{1} = 0.22$ [1]	$\frac{0.28}{14} = 0.02$ [1]	$\frac{0.64}{16} = 0.04$ [1]
ratio	$\frac{0.1}{0.02} = 5$	$\frac{0.22}{0.02} = 11$	$\frac{0.02}{0.02} = 1$	$\frac{0.04}{0.02} = 2$
formula	$C_5H_{11}NO_2$ [1]			

- 42. (a)** heat and weigh [1]
 repeat [1]
 until no further change in mass/two consecutive mass measurements are the same [1] [3]
- (b)** $18.05 - 16.51 = 1.54$ g [1]
- (c)** $\frac{1.54}{44} = 0.035$ [1]
- (d)** 0.035 (1:1 ratio of $MCO_3:CO_2$) [1]
- (e)** $18.05 - 15.11 = 2.94$ g [1]
- (f)** $M_r = \frac{2.94}{0.035} = 84$ [1]
- (g)** $84 - 60 = 24$ [1]
 magnesium/Mg [1] [2]

This is more unusual as it is using the loss in mass from a thermal decomposition to determine the mass and moles of the gas released. The moles of the solid used can be determined using the balanced symbol equation. Mass and moles allow M_r to be calculated in (f) and subtracting the M_r of ' CO_3 ' leaves the M_r of M. Always be careful when looking up relative atomic masses from the Periodic Table in the Data Leaflet as common mistakes would be to look at the atomic number. This would mean chromium would be a common mistake here as its atomic number is 24.

43. (a) $19.60 - 11.92 = 7.68$ g [1]
- (b) $\frac{7.68}{32} = 0.24$ [1]
- (c) $\times 2 = 0.16$ [1]
- (d) $M_r = \frac{19.60}{0.16} = 122.5$ [1]
- (e) $122.5 - 83.5 = 39$ [1]
potassium/K [1] [2]

Formula involving water of crystallisation

44. (a) water chemically bonded into the crystalline structure [1]
- (b) $\text{ZnSO}_4 \cdot 7\text{H}_2\text{O}$ [1]
- (c) 287 [1]
- (d) $\% \text{ water} = \frac{126}{287} \times 100$ [1] = 43.9 % [1] [2]
45. (a) 21.05 g [1]
- (b) $100 - 21.05 = 78.95$ g [1]
- (c) $\frac{21.05}{18} = 1.169$ [1]
- (d) $\frac{78.95}{135} = 0.585$ [1]
- (e) $\frac{1.169}{0.585} = 2$ [1]
 $\text{CuCl}_2 \cdot 2\text{H}_2\text{O}$ [1] [2]

Assuming 100 g here means the percentages are the same as masses and the moles of the anhydrous and the moles of water may be calculated. Dividing the moles of water by the moles of the anhydrous gives the degree of hydration.

46. mass of water = 14.06 g [1]
mass of $\text{Li}_2\text{SO}_4 = 100 - 14.06 = 85.94$ g [1]
moles of water = $\frac{14.06}{18} = 0.781$ [1]
mass of $\text{Li}_2\text{SO}_4 = \frac{85.94}{110} = 0.781$ [1]
 $\frac{0.781}{0.781} = 1$ [1] [5]

47. mass of water = 43.2 g [1]

$$\text{mass of Al(NO}_3)_3 = 100 - 43.2 = 56.8 \text{ g [1]}$$

$$\text{moles of water} = \frac{43.2}{18} = 2.4 \text{ [1]}$$

$$\text{mass of Al(NO}_3)_3 = \frac{56.8}{213} = 0.267 \text{ [1]}$$

$$\frac{2.4}{0.267} = 9 \text{ [1]}$$

[5]

48.

Name	Formula	Relative formula mass (M_r)	Percentage of water by mass (%)
hydrated barium chloride	$\text{BaCl}_2 \cdot 2\text{H}_2\text{O}$	244 [1]	14.75/14.8 [1]
hydrated copper(II) sulfate	$\text{CuSO}_4 \cdot 5\text{H}_2\text{O}$ [1]	250	36 [1]
hydrated nickel(II) sulfate	$\text{NiSO}_4 \cdot 7\text{H}_2\text{O}$ [1]	281 [1]	44.84
hydrated sodium carbonate [1]	$\text{Na}_2\text{CO}_3 \cdot 10\text{H}_2\text{O}$	286 [1]	62.94 [1]

For hydrated copper(II) sulfate, you can work out the degree of hydrated using the relative formula mass. CuSO_4 adds up to 160 so $250 - 160 = 90$ must be the mass of the water. $90 \div 18 = 5$. 18 is the M_r of water.

For hydrated nickel(II) sulfate, if 44.84 g of the compound is water then 44.84 g of water are present in 100 g of the compound and $(100 - 44.84) = 55.16$ g of nickel(II) sulfate. Working out moles below:

$$\text{moles of NiSO}_4 = 55.16 \div 155 = 0.356$$

$$\text{moles of H}_2\text{O} = 44.84 \div 18 = 2.491$$

$$2.491 \div 0.356 = 7$$

49. mass of water = 6.00 – 3.57 = 2.43 g [1]

$$\text{moles of water} = \frac{2.43}{18} = 0.135 \text{ [1]}$$

$$\text{moles of Cr(NO}_3)_3 = \frac{3.57}{238} = 0.015 \text{ [1]}$$

$$\frac{0.135}{0.015} = 9 \text{ so } x = 9 \text{ [1]}$$

[4]

- 50. (a)** does not contain water of crystallisation [1]
- (b)** mass of water = $1.23 - 0.60 = 0.63$ g [1]
 moles of water = $\frac{0.63}{18} = 0.035$ [1]
 moles of $\text{MgSO}_4 = \frac{0.60}{120} = 0.005$ [1]
 $\frac{0.035}{0.005} = 7$ so $x = 7$ [1] [4]
- 51. (a)** heat and weigh [1]
 repeat [1]
 until no further change in mass/two consecutive mass measurements are the same [1] [3]
- (b)** remove all the water of crystallisation [1]
- (c)** mass of water = $20.90 - 18.74 = 2.16$ g [1]
 mass of $\text{Na}_2\text{CO}_3 = 18.74 - 17.15 = 1.59$ g [1]
 moles of water = $\frac{2.16}{18} = 0.12$ [1]
 moles of $\text{Na}_2\text{CO}_3 = \frac{1.59}{106} = 0.015$ [1]
 $\frac{0.12}{0.015} = 8$ [1] [5]
- 52. (a)** heating to constant mass [1]
 ensure all the water of crystallisation removed [1] [2]
- (b)** mass of water = $19.20 - 17.94 = 1.26$ g [1]
 mass of $\text{FeSO}_4 = 17.94 - 16.42 = 1.52$ g [1]
 moles of water = $\frac{1.26}{18} = 0.07$ [1]
 moles of $\text{FeSO}_4 = \frac{1.52}{152} = 0.01$ [1]
 $\frac{0.07}{0.01} = 7$ [1] [5]
- 53. (a)** contains water of crystallisation [1]
- (b)** moles of $\text{Na}_2\text{SO}_4 \cdot 10\text{H}_2\text{O} = \frac{1.61}{322} = 0.005$ [1]
 moles of $\text{Na}_2\text{SO}_4 = 0.005$ [1] (1:1 ratio)
 mass of $\text{Na}_2\text{SO}_4 = 0.005 \times 142 = 0.71$ g [1] [3]
- (c)** $1.61 - 0.71 = 0.9$ g [1]
- (d)** weigh empty container [1]
 weigh container and hydrated sodium sulfate [1]
 heat and weigh [1]
 until two consecutive mass measurements are the same [1] [4]

1.8 Acids, Bases and Salts

Indicators and pH

1.

Solution	Colour with red litmus	Colour with blue litmus	Colour with universal indicator
hydrochloric acid	red	red	red
ammonia solution	blue	blue	blue
sodium hydroxide solution	blue	blue	dark blue/purple
water	red	blue	green
ethanoic acid	red	red	orange/yellow

[1] per row

[5]

2. (a) hydrogen ion [1]

chloride ion [1]

(b) completely ionised in water [1]

(c) sulfuric acid/nitric acid [1]

(d) red [1]

(e) circle around 1 mol/dm^3 [1]

3. (a) C [1]

(b) E [1]

(c) B [1]

(d) D [1]

(e) pink [1]

(f) E [1]

4. (a) universal indicator paper/pH meter [1]

observed colour and compare to colour chart/read off value [1]

(b) lowest pH = W [1]

highest pH = Z [1]

(c) yellow [1]

(d) partially ionised in water [1]

(e) OH^- /hydroxide [1]

5. (a)

Solution	pH	Colour with universal indicator	Colour with methyl orange	Colour with phenolphthalein
J	13	dark blue/purple	yellow	pink
K	3–4	orange	red	colourless
L	7	green	orange	colourless
M	0–2	red	red	colourless
N	10	blue	yellow	pink

- (b) (i) J [1]
(ii) K [1]
(iii) L [1]
(iv) K and M [1]

Where a range of pH values are given in the answers this is to show the acceptable range but you would just give a number in this range. For example for 0–2, 0, 1 and 2 are acceptable answers. Any decimal pH value such as 1.5 is fine too as long as within the range.

6. (a) zinc chloride + hydrogen [1]
(b) sodium oxide/sodium hydroxide [1]
(c) calcium nitrate [1]
(d) sulfuric acid water [1]
(e) aluminium chloride + water [1]

7. (a)

- (i) grey solid disappears [1] colourless solution formed [1] [2]
(ii) green solid disappears [1] blue solution formed [1] [2]
- (b) (i) $\text{Mg} + 2\text{HCl} \rightarrow \text{MgCl}_2 + \text{H}_2$
correct formulae of reactants [1]
correct formulae of products [1]
correct balancing [1] [3]
- (ii) $\text{CuCO}_3 + 2\text{HCl} \rightarrow \text{CuCl}_2 + \text{CO}_2 + \text{H}_2\text{O}$
correct formulae of reactants [1]
correct formulae of products [1]
correct balancing [1] [3]
- (c) thermometer/temperature probe [1]
increase in temperature [1] [2]

(d)

Reaction	Gas produced	Test	Result
magnesium + hydrochloric acid	hydrogen [1]	apply a lit splint [1]	pop [1]
copper(II) carbonate + hydrochloric acid	carbon dioxide [1]	bubble through limewater [1]	colourless to milky [1]

[6]

8. (a)

(i) burette

[1]

(ii) insulation/prevent heat loss

[1]

(iii) prevent it toppling over/stability

[1]

(b) (i)

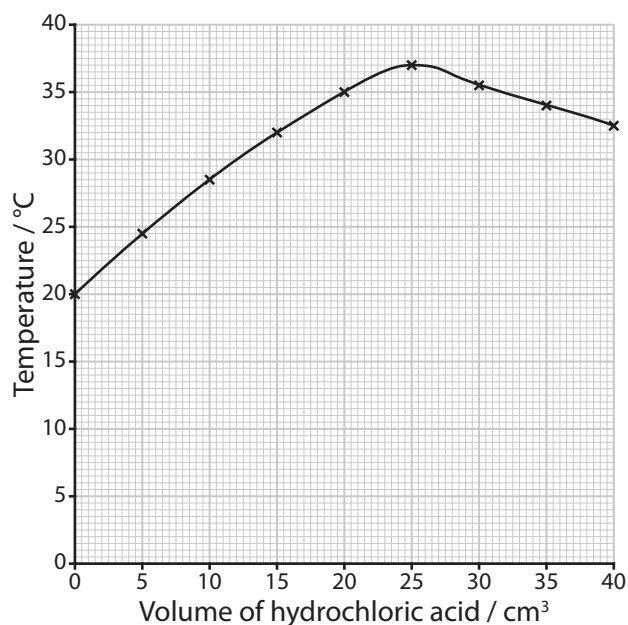

all points plotted correctly [3]

smooth curve [1]

[4]

(ii) 25 cm³

[1]

(iii) 17 °C

[1]

(iv) exothermic as heat is given out/temperature increases

[1]

(c) (i) $\text{NaOH} + \text{HCl} \rightarrow \text{NaCl} + \text{H}_2\text{O}$
 correct formulae of reactants [1]
 correct formulae of products [1]

[2]



9. (a) A = hydrogen [1]
 B = water [1]
 C = carbon dioxide [1] [3]



(c) (i) **Indicative content:**

1. measure a volume of/place sulfuric acid into a conical flask
2. add zinc carbonate until no more fizzing/in excess/solid remains
3. filter to remove the excess zinc carbonate
4. heat the filtrate to reduce the volume
5. allow to cool and crystallise
6. filter to remove the crystals
7. dry between two sheets of filter paper/in a desiccator/in a low temperature oven

Band	Response	Mark
A	Candidates must use appropriate specialist terms to describe fully in a logical sequence the preparation of pure, dry crystals [6 – 7 indicative content points]. Relevant material is organised with a high degree of clarity and coherence. They must use excellent spelling, punctuation and grammar and the form and style are of a very high standard.	[5]–[6]
B	Candidates must use appropriate specialist terms to describe in a logical sequence the preparation of pure, dry crystals [4 – 5 indicative content points]. Relevant material is organised with some clarity and coherence. They use good spelling, punctuation and grammar and the form and style are of a satisfactory standard.	[3]–[4]
C	Candidates describe briefly and partially the preparation of pure, dry crystals [2 – 3 indicative content points]. The organisation of material may lack clarity and coherence. They use limited spelling, punctuation and grammar and they have limited use of specialist terms. The form and style are of limited standard	[1]–[2]
D	A response not worthy of credit	[0]

[6]

(ii) gas produced [1]
easier to see when acid used up/zinc carbonate in excess [1] [2]

(iii) $\text{ZnCO}_3 + \text{H}_2\text{SO}_4 \rightarrow \text{ZnSO}_4 + \text{CO}_2 + \text{H}_2\text{O}$
correct formulae of reactants [1]
correct formulae of products [1]
correct balancing [1] [3]

In the salt preparation in (c)(i), make sure the sequence you use is logical and that you remember to add excess of the solid (in this case zinc carbonate) and then remove the excess by filtration. The points from 4 to 7 are standard for all salt preparations and be careful with the method of drying as well as you need to say between two pieces of filter paper. Paper towels should never be used to dry crystals. Also if you are using a desiccator, make sure you can spell it!

10. (a) $2\text{KOH} + \text{H}_2\text{SO}_4 \rightarrow \text{K}_2\text{SO}_4 + 2\text{H}_2\text{O}$
correct formulae of reactants [1]
correct formulae of products [1]
correct balancing [1] [3]

(b) (i) pipette (allow burette) [1]

(ii) observe the colour change clearly [1]

(iii) pink [1] to colourless [1] [2]

(iv)

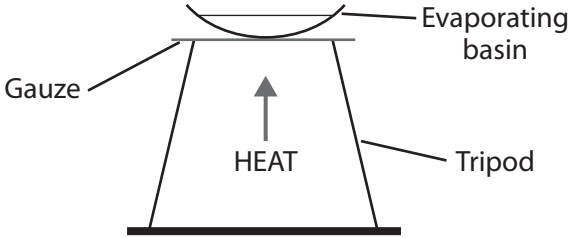

labels for tripod [1]; gauze [1]; evaporating basin [1] [3]

(v) solubility decreases as temperature decreases [1]

(vi) any **two** from:

- dry between two sheets of filter paper
- in a desiccator
- in a low temperature oven

[3]

11. (a) a compound [1] in which some of all of the H⁺ ions in an acid [1] have been replaced by metal ions (or ammonium ions) [1] [3]

(b)

Acid	Other reactant	Name of salt formed	Formula of the salt	Appearance of the solid salt
nitric acid	sodium carbonate	sodium nitrate	NaNO ₃	white solid
sulfuric acid	copper(II) oxide	hydrated copper(II) sulfate	CuSO ₄ ·5H ₂ O	blue solid
hydrochloric acid	potassium hydrogencarbonate	potassium chloride	KCl	white solid
nitric acid	ammonia	ammonium nitrate	NH₄NO₃	white solid

[1] for each correct column [4]

- (c) black [1]

The colours of salt are very important. Group 1 and 2, aluminium and zinc salts (and ammonium salts) are white and form colourless solutions. Copper(II) compounds are mostly coloured. Copper(II) oxide is black, copper(II) carbonate is green, hydrated copper(II) sulfate is blue and anhydrous copper(II) sulfate is white. Anhydrous copper(II) sulfate is used as a test for water in section 1.9.

- (d) (i) $\text{KHCO}_3 + \text{HCl} \rightarrow \text{KCl} + \text{CO}_2 + \text{H}_2\text{O}$
 correct formulae of reactants [1]
 correct formulae of products [1] [2]

- (ii) bubbles/fizzing/effervescence [1]
 solid disappears [1]
 colourless solution formed [1]
 (any indication of heat released max 2) [3]

As you are told that the reaction is endothermic in the question it is important not to state "heat released".

- (iii) thermometer/temperature probe [1]
 decrease in temperature [1] [2]

- (e) (i) $2\text{NH}_3 + \text{H}_2\text{SO}_4 \rightarrow (\text{NH}_4)_2\text{SO}_4$
 correct formulae of reactants [1]
 correct formula of product [1]
 correct balancing [1] [3]

- (ii) exothermic [1]

- (iii) corrosive [1]

1.9 Chemical Analysis

1. (a) D [1]
 (b) C [1]
 (c) E [1]
 (d) B [1]

Remember an element contains only one type of atom. It doesn't matter if the atoms are bonded together as in O_2 , Cl_2 etc. These are elements. Molecules of compounds contain different types of atoms bonded together.

2. (a) It contains more than one substance/water is mixed with other substances [1]

(b) any name and formula from:

calcium hydrogencarbonate	$Ca(HCO_3)_2$
calcium chloride	$CaCl_2$
calcium nitrate	$Ca(NO_3)_2$
calcium sulfate	$CaSO_4$
magnesium hydrogencarbonate	$Mg(HCO_3)_2$
magnesium chloride	$MgCl_2$
magnesium nitrate	$Mg(NO_3)_2$
magnesium sulfate	$MgSO_4$
sodium hydrogencarbonate	$NaHCO_3$
sodium chloride	$NaCl$
sodium nitrate	$NaNO_3$
sodium sulfate	Na_2SO_4

[2]

(c) (i)

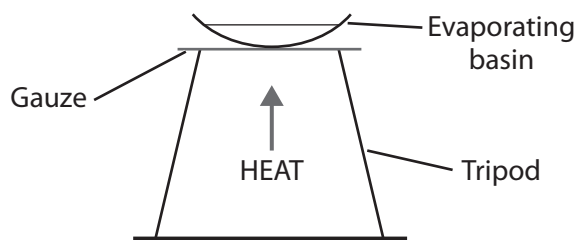

labels for tripod [1]; gauze [1]; evaporating basin [1]

[3]

(ii) $\frac{170}{40} = 4.25 \text{ mg}$

[1]

(d) pH meter

[1]

A pH meter must have been used as the pH is quoted to 1 decimal place. Narrow range universal indicator paper also works but is not commonly used. This is an example of an overlap question where questions from other sections may be incorporated as you progress through the book. It is important to be able to link across sections within a unit.

- (e) anhydrous copper(II) sulfate [1]
white [1] to blue [1] [3]
- 3 (a) distillation [1]
- (b) evaporation/recrystallisation [1]
- (c) using a separating funnel [1]
- (d) (i) filtration [1]
- (ii) A = filter paper [1]
B = filter funnel [1]
C = conical flask [1] [3]
- (iii) solid X = residue [1]
liquid Y = filtrate [1] [2]
- (iv) solid X = magnesium oxide [1]
liquid Y = potassium iodide solution [1] [2]
4. (a) a mixture designed as a useful product [1] formed by mixing several different substances in carefully-measured quantities [1] ensuring the mixture has the required properties [1] [3]
- (b) alloy [1]
- (c) medicine/fertiliser [1]
- (d) (i) higher percentage of gold, higher melting point [1]
- (ii) circle around 1055 °C [1]

Impurities cause a decrease in melting point and an increase in boiling point.

5. (a) $\frac{23.4}{58.5} = 0.4 \text{ mol}$ [1]
- (b) The boiling point of the mixture is greater than 100 °C ✓ [1]
- (c) soluble [1]
solute [1]
solvent [1]
solution [1] [4]
- (d) (i) water which is safe to drink [1]
- (ii) **Indicative content**
- | | |
|----------------------|--|
| 1. filtration [1] | removes solid particles [1] |
| 2. sedimentation [1] | aluminium sulfate added [1] |
| | small particles coagulate together [1] |
| 3. chlorination [1] | kills bacteria [1] |

Band	Response	Mark
A	Candidates must use appropriate specialist terms to describe how water is made potable [5 – 7 indicative content points]. Relevant material is organised with a high degree of clarity and coherence. They must use excellent spelling, punctuation and grammar and the form and style are of a very high standard.	[5]–[6]
B	Candidates must use appropriate specialist terms to describe how water is made potable [3 – 4 indicative content points]. Relevant material is organised with some clarity and coherence. They use good spelling, punctuation and grammar and the form and style are of a satisfactory standard.	[3]–[4]
C	Candidates describe briefly and partially how water is made potable [at least 2 indicative content points]. The organisation of material may lack clarity and coherence. They use limited spelling, punctuation and grammar and they have limited use of specialist terms. The form and style are of limited standard	[1]–[2]
D	A response not worthy of credit	[0]

[6]

(i) desalination/distillation

[1]

6. (a) A = thermometer [1]
B = (Liebig) condenser [1]

[2]

(b) distillate

[1]

(c) water boils [1]
and condenses [1]

[2]

(d) anti-bump(ing) granules

[1]

(e) fractional (distillation) or add a fractionating column

[1]

7. (a) pencil line near bottom of chromatography paper [1]
spot of dye applied to base line [1]
place in small volume of solvent/dilute hydrochloric acid [1]
remove when solvent near the top [1]
mark solvent front in pencil [1]

max [4]

(b) it does not dissolve in the solvent

[1]

(c) distance moved by spot = 1.2 cm [1]
distance moved by solvent = 5.4 cm [1]

$$R_f = \frac{1.2}{5.4} = 0.22 [1]$$

[3]

- (d) X [1]
- (e) dye dissolves in mobile phase [1]
 components move based on solubility in mobile phase [1]
 and attachment to stationary phase [1] [3]
8. (a) silver chloride/AgCl [1]
- (b) $\text{Cu}^{2+}(\text{aq}) + 2\text{OH}^{-}(\text{aq}) \rightarrow \text{Cu}(\text{OH})_2(\text{s})$
 correct formulae of reactants [1]
 correct formula of product [1]
 correct balancing [1]
 correct state symbols [1] [4]
- (c) nichrome wire [1]
 dipped in concentrated hydrochloric acid [1]
 place in sample and into blue Bunsen burner flame [1] [3]
- (d) cation: Cu^{2+} /copper(II) ion [1]
 anion: Cl^{-} /chloride ion [1] [2]
- (e) CuCl_2 [1]
9. (a)
- (i) sulfate ions/ SO_4^{2-} [1]
- (ii) iron(II) ions/ Fe^{2+} [1]
- (iii) iodide ions/ I^{-} [1]
- (iv) carbonate ions/ CO_3^{2-} [1]
- (v) potassium ions/ K^{+} [1]
- (i) aluminium ions/ Al^{3+} [1]

The command word “identify” is used so that you can either write the name of the ion or give the correct formula. Be careful with ions like iodide as iodine ions is a common incorrect answer.

- (b) (i) $\text{Ba}^{2+} + \text{SO}_4^{2-} \rightarrow \text{BaSO}_4$
 correct formulae of reactants [1]
 correct formula of product [1] [2]
- (iii) iron(II) hydroxide/ $\text{Fe}(\text{OH})_2$ [1]
- (iv) silver iodide/AgI [1]
- (v) carbon dioxide/ CO_2 [1]
- (vi) $\text{Al}^{3+} + 3\text{OH}^{-} \rightarrow \text{Al}(\text{OH})_3$
 correct formulae of reactants [1]
 correct formula of product [1]
 correct balancing [1] [3]

1.10 Solubility

1. (a) 80 °C [1]

(b) to ensure the results were reliable [1]

Be careful with terms like reliable, valid and accurate. Reliability is about whether or not the results of the experiment are obtained again when it is repeated. This experiment was reliable as the results from the repeat were similar. Accuracy is related to the method used to obtain accurate results for example weighing the mass of water. Validity is about the overall design of the experiment and if it will give you valid results. A reasonable range of masses of the solid would produce a wide range of solubility temperatures. A range of temperatures between for example 70 and 75 °C would not be sufficient to establish a trend in solubility or plot a solubility curve. The experiment would not be valid.

(c) $4 \times 10 = 40$ (g/100 g water) [1]

(d) water could be lost by evaporation between the experiments [1]
use fresh 10 g of water [1] [2]

2. (a) mass of solid/solute [1]
which saturates 100 g of water [1]
at a particular temperature [1] [3]

(b) (i)

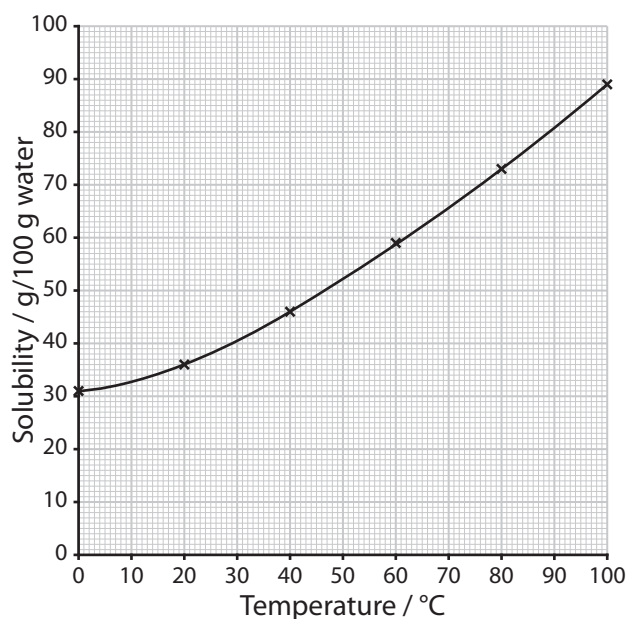

all point plotted correctly [3]
smooth curve [1] [4]

(ii) 65.5 (65 – 66) (g/100 g water) [1]

(iii) mass in solution at lower temperature = $150 - 60 = 90$ g [1]
solubility = $90 \div 2.5 = 36$ g/100 g water [1]
temperature from graph = 20 °C [1] [3]

(iv) solubility at 50 °C = 52 g/100 g water [1]

solubility at 25 °C = 38 g/100 g water [1]

$$52 - 38 = 14 \text{ g [1]}$$

$$\frac{14}{100} \times 40 = 5.6 \text{ g [1]}$$

[4]

3. (a) 43 °C

[1]

(b) as temperature increases solubility increases

[1]

(c) solubility of potassium nitrate at 20 °C = 11 (g/100 g water) [1]

$$11 \div 100 \times 80 = 8.8 \text{ g [1] required to saturate 80 g}$$

[2]

(d) solubility at 90 °C = 46 (g/100 g water) [1]

solubility at 40 °C = 14 (g/100 g water) [1]

$$46 - 14 = 32 \text{ g [1]}$$

$$32 \div 4 = 8 \text{ g [1]}$$

[4]

(e) (i) solubility of potassium chlorate at 60 °C = 24 [1]

solubility of potassium nitrate at 60 °C = 18.2 [1]

solubility of potassium chlorate at 70 °C = 30.5 [1]

[3]

(ii) A is unsaturated; 20 g present in 100 g water < 24 g [1]

B is saturated; 20 g present in 100 g water > 18.2 g [1]

C is saturated; 4 g present in 10 g water > 3.05 g [1] (or 40 g > 30.5 g) [1]

[3]

4. (a) hydrochloric acid

[1]

(b) solubility decreases

[1]

(c) (i)

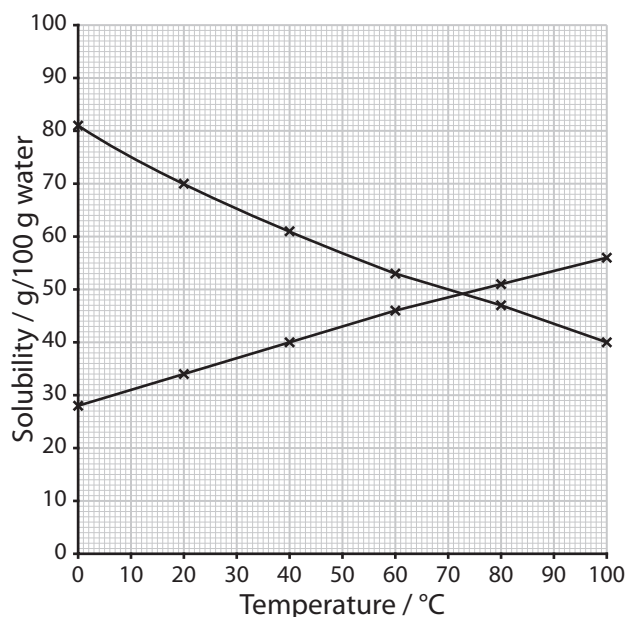

all point plotted correctly [3]

smooth curve/line [1]

[4]

(ii) 72–73 °C [1]

(iii) solubility at 30 °C = 37 (g/100g water) [1]

$$\frac{148}{37} \times 4 [1]$$

$$100 \times 4 = 400 \text{ g} [1] \quad [3]$$

(iv) solubility at 20 °C = 70 g/100 g water [1]

$$\frac{70}{100} \times 60 = 42 \text{ g} [1] \quad [2]$$

(v) solubility at 50 °C = 43 (g/100 g water) [1]

$$43 - 12 = 31 [1] \text{ (or } 43 \div 2 = 21.5 - 6 = 15.5 \times 2 = 31)$$

$$\text{temperature} = 10 \text{ °C} [1] \quad [3]$$

Unit 2:

Further Chemical Reactions,
Rates and Equilibrium, Calculations
and Organic Chemistry

Answers

2.1 Metals and Reactivity Series

1. (a)
- (i) calcium [1]
 - (ii) copper [1]
 - (iii) zinc [1]
 - (iv) calcium [1]
 - (v) potassium [1]
- (b) (i) $2\text{Mg} + \text{O}_2 \rightarrow 2\text{MgO}$
 correct formulae of reactants [1]
 correct formula of product [1]
 correct balancing [1] [3]
- (ii) $2\text{Na} + 2\text{H}_2\text{O} \rightarrow 2\text{NaOH} + \text{H}_2$
 correct formulae of reactants [1]
 correct formulae of products [1]
 correct balancing [1] [3]
- (iii) $\text{Zn} + \text{H}_2\text{O} \rightarrow \text{ZnO} + \text{H}_2$
 correct formulae of reactants [1]
 correct formulae of products [1] [2]
- (iv) $4\text{K} + \text{O}_2 \rightarrow 2\text{K}_2\text{O}$
 correct formulae of reactants [1]
 correct formula of product [1]
 correct balancing [1] [3]
2. (a) A = delivery tube [1]
 B = gas jar [1]
 C = beehive shelf [1] [3]
- (b) to generate steam [1]
- (c) white light [1]
 white solid formed [1] [2]
- (d) $\text{Mg}(\text{s}) + \text{H}_2\text{O}(\text{g}) \rightarrow \text{MgO}(\text{s}) + \text{H}_2(\text{g})$
 correct formulae of reactants [1]
 correct formulae of products [1]
 correct state symbols [1] [3]
- (e) prevent suck back [1]

- (b) (i) $2\text{K(s)} + 2\text{H}_2\text{O(l)} \rightarrow 2\text{KOH(aq)} + \text{H}_2\text{(g)}$
 correct formulae of reactants [1]
 correct formulae of products [1]
 correct balancing [1]
 correct state symbols [1] [4]
- (ii) moves on the surface [1]
 crackle/explosion [1]
 potassium disappears [1]
 colourless solution formed [1]
 lilac flame [1] **max** [3]

5. Indicative content

- plants grow and extract copper compounds from soil [1]
- plants are burned to create an ash rich in copper compounds [1]
- ash reacted with sulfuric acid [1]
- produces a solution of copper compounds [1]
- scrap iron added to solution [1]
- displaces the copper/produce solid copper [1]

Band	Response	Mark
A	Candidates must use appropriate specialist terms to describe phytomining [5 – 6 indicative content points]. Relevant material is organised with a high degree of clarity and coherence. They must use excellent spelling, punctuation and grammar and the form and style are of a very high standard.	[5]–[6]
B	Candidates must use appropriate specialist terms to describe phytomining [3 – 4 indicative content points]. Relevant material is organised with some clarity and coherence. They use good spelling, punctuation and grammar and the form and style are of a satisfactory standard.	[3]–[4]
C	Candidates describe briefly and partially phytomining [at least 2 indicative content points]. The organisation of material may lack clarity and coherence. They use limited spelling, punctuation and grammar and they have limited use of specialist terms. The form and style are of limited standard.	[1]–[2]
D	A response not worthy of credit	[0]

[6]

6. (a) outer electron is further from the nucleus/more shielding in potassium [1] outer electron is less attracted to the nucleus/lost more readily in potassium [1] [2]
- (b) $\text{Ca} \rightarrow \text{Ca}^{2+} + 2\text{e}^-$
 Ca on left of arrow and Ca^{2+} on right [1]
 + e^- on right (or $-\text{e}^-$ on left) [1]
 correct balancing [1] [3]
- (c) aluminium is more reactive [1] than iron [1] [2]

2.2 Redox, Rusting and Iron

1. (a) element = oxygen [1]
 compound = water [1] [2]
- (b) hydrated [1] iron(III) oxide [1] [2]
- (c) flaky [1] brown [1] solid [1] **max** [2]
- (d) iron gains oxygen [1]
 gain of oxygen is oxidation [1]
 (iron loses electrons [1]; loss of electrons is oxidation [1]) [2]

For all oxidation and reduction questions, ensure you state what loses/gains oxygen/hydrogen/electrons for the first mark and then add the definition for oxidation/reduction for the second mark.

2. (a) bromine gains hydrogen [1]
 gain of hydrogen is reduction [1] [2]
- (b) carbon monoxide/CO [1]
- (c) Fe₂O₃/iron(III) oxide [1]
- (d) chlorine gains electrons [1]
 gain of electrons is reduction [1] [2]
- (e) calcium loses electrons [1]
 loss of electrons is oxidation [1] [2]
3. (a) $2\text{H}_2\text{S} + 3\text{O}_2 \rightarrow 2\text{SO}_2 + 2\text{H}_2\text{O}$
 correct formulae of reactants [1]
 correct formulae of products [1]
 correct balancing [1] [3]

Unusual balanced symbol equations are common in Unit 2 and 3 so be prepared to be able to write the formulae and balance them. If you find the balancing difficult make sure you write all the correct formulae as you will still get 2 of the marks.

- (b) sulfur [1]
- (c) sulfur gains oxygen [1]
 gain of oxygen is oxidation [1]
 (or sulfur loses hydrogen [1] and loss of hydrogen is oxidation [1]) [2]
- (d) fluorine gains hydrogen [1]
 gain of hydrogen is reduction [1] [2]

4. (a) boiling the water removed oxygen [1]
olive oil prevents oxygen re-entering [1] [2]
- (b) anhydrous calcium chloride absorbs water/moisture [2]
(no water/moisture present = [1]) [2]
- (c) oxygen [1]
water/moisture [1] [2]
5. (a) painting/plastic coating/metal coating or plating/oil/grease **max** [2]
- (b) zinc is more reactive [1] than iron [1] [2]
- (c) magnesium [1]
- (d) galvanising [1]

6. (a)

Main chemical component required in Blast Furnace	Material added
iron(III) oxide	haematite/iron ore [1]
calcium carbonate	limestone [1]
carbon	coke [1]
oxygen	(hot) air [1]

[4]

- (b) $C + O_2 \rightarrow CO_2$
correct formulae of reactants [1]
correct formulae of product [1]
- $CO_2 + C \rightarrow 2CO$
correct formulae of reactants [1]
correct formula of product [1]
correct balancing [1] [5]
- (c) reducing agent [1]
- (d) $Fe_2O_3 + 3CO \rightarrow 2Fe + 3CO_2$
correct formulae of reactants [1]
correct formulae of products [1]
correct balancing [1] [3]
- (e) (i) thermal decomposition [1]
- (ii) $CaCO_3 \rightarrow CaO + CO_2$
correct formula of reactant [1]
correct formulae of products [1] [2]

- 8. (a)** $\text{Zn} + \text{Fe}(\text{NO}_3)_2 \rightarrow \text{Zn}(\text{NO}_3)_2 + \text{Fe}$
correct formulae of reactants [1]
correct formulae of products [1] [2]
- (b)** displacement [1]
- (c)** $\text{Zn} + \text{Fe}^{2+} \rightarrow \text{Zn}^{2+} + \text{Fe}$
correct formulae of reactants [1]
correct formulae of products [1] [2]
- (d) (i)** $\text{Zn} \rightarrow \text{Zn}^{2+} + 2\text{e}^-$
 Zn^{2+} on left of arrow and Zn on right [1]
+ e^- on right (or - e^- on left) [1]
correct balancing [1] [3]
- (ii)** zinc loses electrons [1]
loss of electrons is oxidation [1] [2]
- (e) (i)** $\text{Fe}^{2+} + 2\text{e}^- \rightarrow \text{Fe}$
 Fe^{2+} on left of arrow and Fe on right [1]
+ e^- on left [1]
correct balancing [1] [3]
- (iii)** iron(II) ions gain electrons [1]
gain of electrons is reduction [1] [2]
- (d)** redox is oxidation and reduction occurring simultaneously in the same reaction [1]
exothermic reaction releases heat [1] [2]

2.3 Rates of Reaction

1. (a) zinc oxide [1]
longest time/slowest rate [1] [2]
- (b) substance which increases the rate of the chemical reaction [1]
without being used up [1] [2]
- (c) minimum energy required for particles to react [1]
2. (a) gas syringe [1]
- (b) (i) $\frac{0.39}{65} = 0.006 \text{ mol}$ [1]
- (iii) hydrochloric acid [1]
- 0.01 mol of HCl reacts with 0.005 mol of Zn so Zn in excess and HCl is limiting reactant
- (iv) $\frac{0.01}{2} = 0.005 \text{ mol}$ [1]
- (v) $0.005 \times 24000 = 120 \text{ cm}^3$ [1]
- (f) impure zinc/not all zinc reacted/not all gas measured [1]
3. (a) $\text{CaCO}_3 + 2\text{HNO}_3 \rightarrow \text{Ca}(\text{NO}_3)_2 + \text{CO}_2 + \text{H}_2\text{O}$
correct formulae of reactants [1]
correct formulae of products [1]
correct balancing [1] [3]

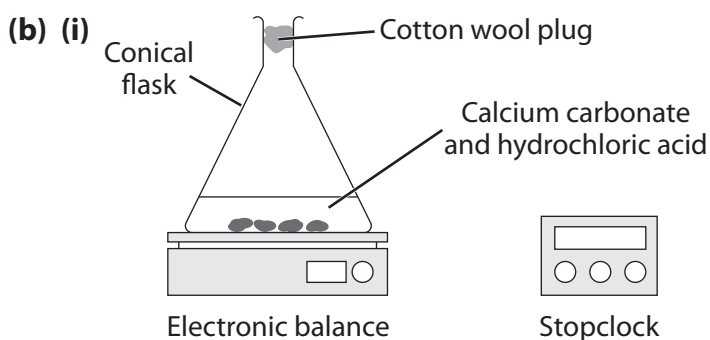

conical flask with cotton wool plug [1]
on electronic balance [1]
calcium carbonate and hydrochloric acid in contact in flask [1]
stopclock [1]

It is very important with all diagram to label everything and to use assembled apparatus. The conical flask must be on the electronic balance and you will need a stopclock (or stopwatch) to time the reaction.

(ii) $144.70 - 143.82 = 0.88 \text{ g}$ [1]

(iii) 70 s [1]

- (iv) starts at same point, remains lower and levels off at same mass but earlier [1]
example below:

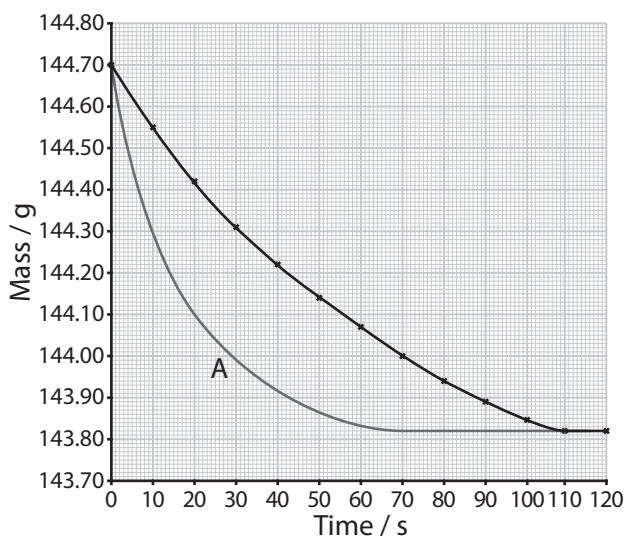

Make sure you label the line as directed in the question. This is particularly important when there are two lines to sketch on a graph so it good practice to do it, if directed.

(v) moles of $\text{CaCO}_3 = \frac{0.5}{100} = 0.005 \text{ mol}$ [1]

moles of $\text{CO}_2 = 0.005$ [1]

mass of $\text{CO}_2 = 0.005 \times 44 = 0.22 \text{ g}$ [1]

[3]

- (c) rate of reaction decreases [1]

surface area to volume ratio decreases [1]

less contact between solid and acid [1]

[3]

Using larger solid pieces would slow down the reaction. Powdered calcium carbonate reacts faster than larger solid pieces such as marble chips.



correct formulae of reactants [1]

correct formulae of products [1]

correct balancing [1]

[3]

(b) (i) $\frac{1}{\text{time}}$

[1]

(ii) time = 20 [1] rate = 0.05 [1]

[2]

(iii) rate decreases [1]

fewer particles [1]

fewer successful collisions [1]

in a given period of time [1]

[4]

(iv) 0.1

[1]

5. (a)

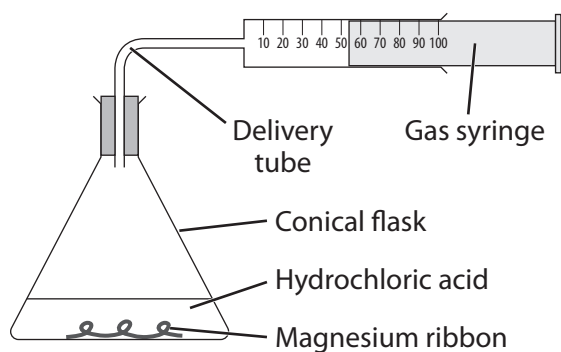

conical flask sealed [1]

containing magnesium and hydrochloric acid [1]

delivery tube [1]

gas syringe [1]

[4]

(b) (i) 58 – 60 s

[1]

(ii) circle around 0 – 10 s

[1]

(iii) 75 cm³

[1]

(iv) starts at 0,0; stays above line; levels off at same volume but earlier

[1]

Example below:

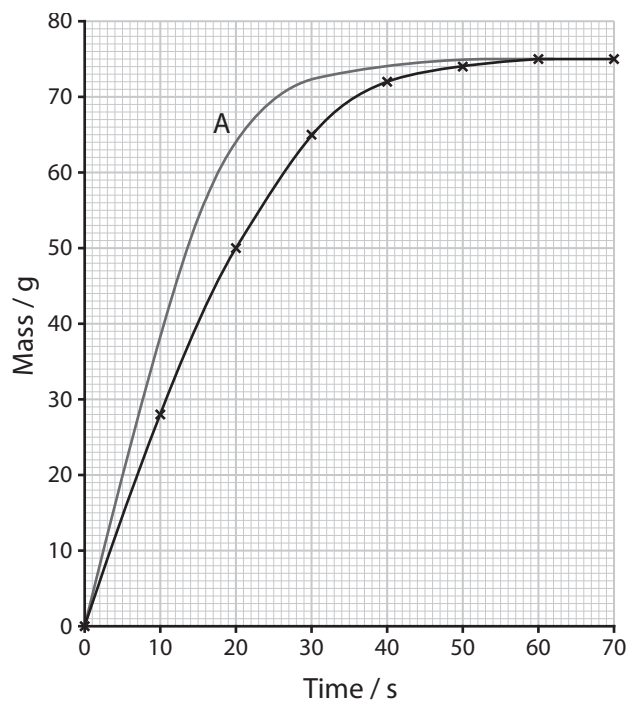

- (v) starts at 0,0; remains lower [1]
levels off at 60 cm³ [1]
Example below:

[2]

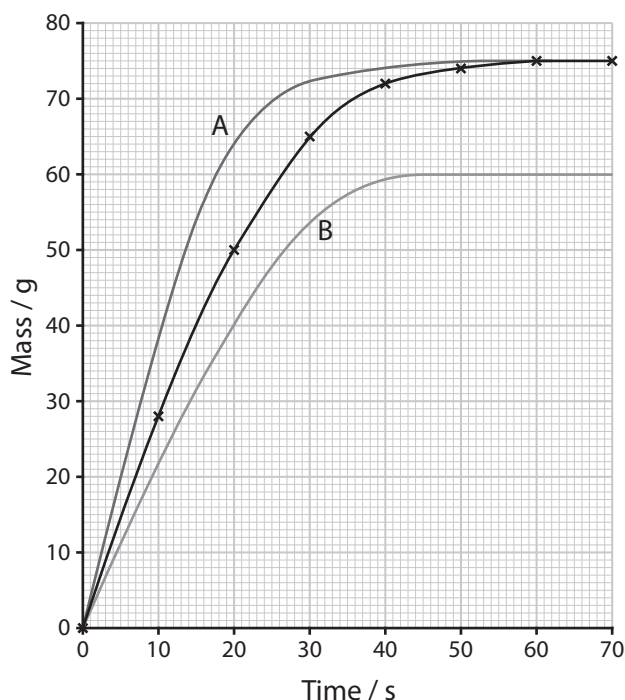

6. (a) $2\text{H}_2\text{O}_2(\text{aq}) \rightarrow 2\text{H}_2\text{O}(\text{l}) + \text{O}_2(\text{g})$
correct formula of reactant [1]
correct formulae of products [1]
correct balancing [1]
correct state symbols [1]

[4]

(b) manganese(IV) oxide/manganese dioxide

[1]

(c) substance which increases the rate of a chemical reaction [1]
without being used up [1]

[2]

(d) provides an alternative reaction pathway [1]
of lower activation energy [1]

[2]

(e) (i) 88–90 s

[1]

(ii) $127.5 - 127.02 = 0.48 \text{ g}$

[1]

(iii) starts at same point, remains lower and levels off at same mass but earlier
and labelled A

[1]

Example below:

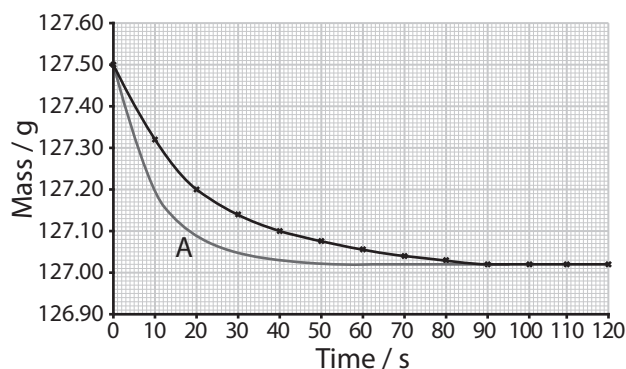

(iv) 0.4 g [1]

(v) starts at same point; remains higher [1]
 levels off at 127.1 g [1] labelled B [2]
 Example below:

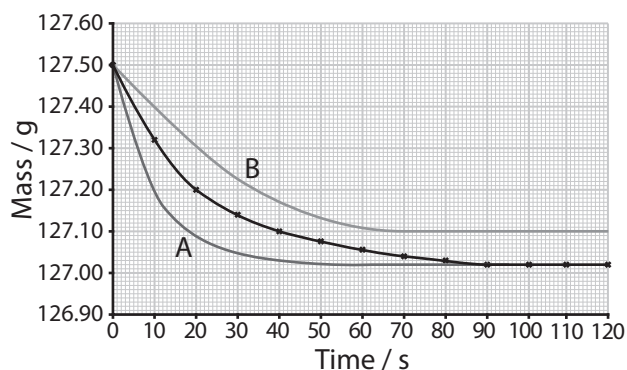

(vi) 1.0 g [1]
 catalyst is not used up [1] [2]

7. (a)

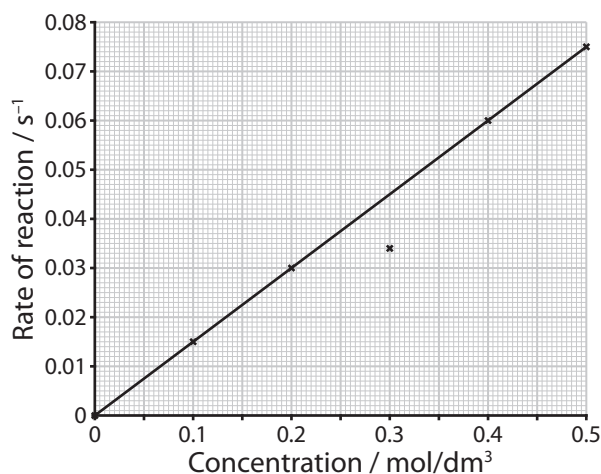

straight line [1]
 ignoring 0.3 mol/dm³ [1] [2]

(b) (i) 0.3 mol/dm³ [1]

(ii) repeat 0.3 mol/dm³ experiment [1]

(c) (i) no more fizzing [1]

It is not possible to say "when the magnesium remains" here as the magnesium is in excess so the only way to determine the time taken for the reaction to be complete is to wait until there is no more fizzing.

(ii) $\frac{1}{0.015}$ [1] = 66.67 s [1] [2]

As the units of rate are s⁻¹, it would be assumed that the time taken for the reaction to be completed is measured and rate is calculated using 1/time. Read the rate from the graph and then convert back to a time in seconds.

- (d) (i)** as concentration increases, rate increases [1]
- (ii)** any two from:
mass/moles of magnesium [1]
volume of hydrochloric acid [1]
temperature [1] [2]

Be careful when comparing reactions of different substances as the moles of the controlled variables should be the same. In this reaction mass or moles of magnesium are accepted as the same substance is used so the same mass is equal to the same moles. If different metals were used, the same moles of different metals should be used as well as the same division of the metals (meaning the same solid particle size).

- (iii)** concentration of hydrochloric acid [1]
- (iv)** time/rate of reaction [1]

4. (a) yield of ammonia decreases [1]
- (b) yield of ammonia increases [1]
- (c) if a change is made to the conditions of a system at equilibrium [1]
the position of equilibrium moves to oppose that change in conditions [1] [2]
- (d) position of equilibrium moves to the left [1]
reverse reaction is endothermic/absorbs the heat [1] [2]
- (e) position of equilibrium moves to the right [1]
fewer moles of gas/smaller volume on right [1] [2]
- (f) (i) 36 % [1]
- (ii) higher pressure is:
expensive to apply/risk of explosion/thick walled vessels to contain it [1]
lower temperature would mean a slower rate of reaction/temperature used is a
compromise temperature [1] [2]

A higher temperature is used to make sure the rate of reaction is high enough without compromising the yield too much.

5. (a) reaction is endothermic as energy change is positive [1]

(b)

A catalyst would have no effect on the yield of hydrogen iodide

✓

The equilibrium is homogeneous

An increase in temperature would increase the yield of hydrogen iodide

✓

A decrease in temperature would increase the yield of hydrogen iodide

[1] per tick; extra ticks [-1]

[2]

6. (a) position of equilibrium moves to the right [1]
fewer moles of gas/smaller volume on right [1] [2]
- (b) D [1]
- (c) lower temperature would mean a slower rate of reaction/temperature used is a compromise
temperature [1]
- (d) all reactants and product are gases [1]
homogeneous means all in same state [1] [2]
- (e) increases the rate of reaction/equilibrium achieved more rapidly [1]

7. (a) $\text{NaOH} + \text{HBr} \rightarrow \text{NaBr} + \text{H}_2\text{O}$
correct formulae of reactants [1]
correct formulae of products [1] [2]
- (b) NaOH absorbs the HBr/less HBr [1]
position of equilibrium moves to the left [1]
to replace the HBr [1]
less red-brown bromine [1] [4]

2.5 Organic Chemistry

1. (a) same general formula [1]
 differ by a CH_2 unit/group [1]
 similar chemical properties [1]
 gradation in physical properties [1]

max [3]

(b) only contains hydrogen and carbon (atoms) [1]

(c) $\text{C}=\text{C}$ [1]

(d) reactive group in a molecule [1]

(e) $\text{C}_n\text{H}_{2n+2}$ [1]

(f)

Name	Molecular formula	Structural formula	State at room temperature
	C_2H_6	<pre> H H H-C-C-H H H </pre>	
propene		<pre> H H-C=C-C-H H H H </pre>	gas
butane	C_4H_{10}		gas

[1] for each complete column

[4]

2. (a) C_4H_8 [1]

(b) alkenes [1]

(c) but-1-ene [1]

(d) orange solution [1] changes to colourless [1] [2]

(e) carbon monoxide [1]
 soot/carbon [1]
 water [1]

[3]

Marks will be taken off here for additional incorrect products of incomplete combustion. Hydrogen is a common incorrect answer.

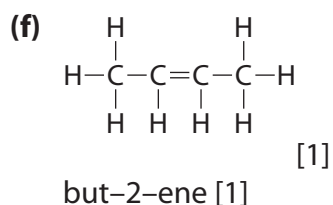

3. (a) fractional [1] distillation [1] [2]
- (b) A = petrol [1]
 B = kerosene [1]
 C = diesel [1] [3]
- (c) will eventually run out/limited [1]
- (d) naphtha: manufacture plastics/chemicals [1]
 bitumen: surface roads/roofs [1] [2]

Make sure you know the fractions listed in the specification which are obtained from crude oil and their uses as this is often poorly recalled.

- (e) (i) $\text{C}_n\text{H}_{2n+2}$ [1]
- (ii) C_3H_8 [1] propane [1] [2]
- (iii) $\text{CH}_4 + 2\text{O}_2 \rightarrow \text{CO}_2 + 2\text{H}_2\text{O}$
 correct formulae of reactants [1]
 correct formulae of products [1]
 correct balancing [1] [3]
4. (a) substance which reacts with oxygen [1]
 forming oxides [1]
 and releasing heat [1] [3]
- (b) C_8H_{18} [1]
- (c) $2\text{C}_4\text{H}_{10} + 13\text{O}_2 \rightarrow 8\text{CO}_2 + 10\text{H}_2\text{O}$
 (or $\text{C}_4\text{H}_{10} + 6\frac{1}{2}\text{O}_2 \rightarrow 4\text{CO}_2 + 5\text{H}_2\text{O}$)
 correct formulae of reactants [1]
 correct formulae of products [1]
 correct balancing [1] [3]
- (d) does not contain C=C [1]
- (e) but-1-ene/but-2-ene [1]
- (f) refinery gases [1]
- (g) carbon monoxide [1]

5. (a) D [1]
- (b) C and D [1]
- (c) A and E [1]
- (d) B and F [1]
- (e) A = propan-1-ol [1]
 B = ethanoic acid [1]
 C = chloroethene/vinyl chloride [1]
 D = but-2-ene [1]
 E = methanol [1]
 F = butanoic acid [1] [6]

- (f) (i) addition [1]

Do not write "additional" here as an answer as it will not be credited.



correct structural formula of monomer on left [1]

correct structural formula of polymer on right [1]

n before monomer and n after polymer [1] [3]

- (iii) poly(chloroethene)/PVC [1]

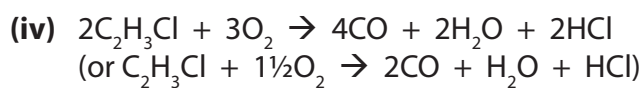

correct formulae of reactants [1]

correct formulae of products [1]

correct balancing [1] [3]

6. (a) $\text{C}_6\text{H}_{14} \rightarrow \text{C}_4\text{H}_{10} + \text{C}_2\text{H}_4$
 correct formula of reactant [1]
 correct formula of products [1] [2]

- (b) ethene [1]

- (c) breaks down large hydrocarbon molecules [1]
 into smaller more useful ones [1] [2]

7. (a) $2\text{C}_2\text{H}_6 + 7\text{O}_2 \rightarrow 4\text{CO}_2 + 6\text{H}_2\text{O}$
 (or $\text{C}_2\text{H}_6 + 3\frac{1}{2}\text{O}_2 \rightarrow 2\text{CO}_2 + 3\text{H}_2\text{O}$)
 correct formulae of reactants [1]
 correct formulae of products [1]
 correct balancing [1] [3]

- (b) limewater [1]
change from colourless [1] to milky [1] [3]
- (c) anhydrous copper(II) sulfate [1]
change from white [1] to blue [1] [3]
- (d) any **two** from:
sea level rises [1]
flooding of low level areas [1]
climate change [1] [2]
8. (a) Reaction 1: steam [1]
Reaction 2: acidified potassium dichromate [1]
Reaction 3: hydrogen [1] [3]
- (b) oxidation [1]
- (c) Reaction 1: ethanol [1]
Reaction 2: ethanoic acid [1]
Reaction 3: ethane [1] [3]
- (d) (i)
$$\left[\begin{array}{cc} \text{H} & \text{H} \\ | & | \\ -\text{C} & -\text{C}- \\ | & | \\ \text{H} & \text{H} \end{array} \right]_n$$
 [1]
- (ii) polythene or poly(ethene) [1]
- (iii) landfill [1]
incineration [1]

Make sure you use the correct terms for these two method of disposal of polymers. A description will not be accepted such as "bury them in land" or "burn them". Also remember that recycling is not a method of disposal of polymers.

9. (a) (i) oxidation [1]
- (ii) acidified potassium dichromate (solution) [1]
orange to green [1] [2]
- (iii)
$$\begin{array}{c} \text{O} \\ || \\ \text{H}-\text{C} \\ | \\ \text{OH} \end{array}$$
 [1]
- (b) (i) $\text{C}_2\text{H}_5\text{OH} + 3\text{O}_2 \rightarrow 2\text{CO}_2 + 3\text{H}_2\text{O}$
correct formulae of reactants [1]
correct formulae of products [1]
correct balancing [1] [3]
- (iii) clean blue flame [1]
- (c) (i) orange solution [1] changes to colourless [1] [2]
- (ii) C_3H_6 [1]

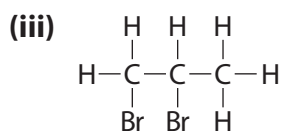

[1]

Although you are not expected to know the name of the product from the reaction of bromine water with alkenes, you can apply your knowledge of the names of organic compounds including the position of the bromine atoms and the structure of propane.

(iv) contains C=C

[1]

10.

Name	Molecular formula	Structural formula	State at room temperature and pressure
	CH ₄		gas
	C ₃ H ₈	$ \begin{array}{c} \text{H} \quad \text{H} \quad \text{H} \\ \quad \quad \\ \text{H}-\text{C}-\text{C}-\text{C}-\text{H} \\ \quad \quad \\ \text{H} \quad \text{H} \quad \text{H} \end{array} $	
butane		$ \begin{array}{c} \text{H} \quad \text{H} \quad \text{H} \quad \text{H} \\ \quad \quad \quad \\ \text{H}-\text{C}-\text{C}-\text{C}-\text{C}-\text{H} \\ \quad \quad \quad \\ \text{H} \quad \text{H} \quad \text{H} \quad \text{H} \end{array} $	
propene		$ \begin{array}{c} \text{H} \\ \\ \text{H}-\text{C}=\text{C}-\text{C}-\text{H} \\ \quad \quad \\ \text{H} \quad \text{H} \quad \text{H} \end{array} $	
but-1-ene	C ₄ H ₈		
but-2-ene	C ₄ H ₈		
methanol	CH ₃ OH		
	C ₃ H ₇ OH	$ \begin{array}{c} \text{H} \quad \text{H} \quad \text{H} \\ \quad \quad \\ \text{H}-\text{C}-\text{C}-\text{C}-\text{OH} \\ \quad \quad \\ \text{H} \quad \text{H} \quad \text{H} \end{array} $	
propan-2-ol	C ₃ H ₇ OH		
butanoic acid			liquid

[1] per correct row

[10]

11. (a) a long chain molecule formed from smaller molecules [1]

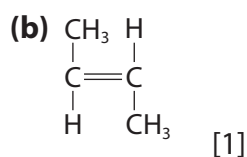

[1]

but-2-ene [1]

[2]

(c) addition [1]

[1]

(d) landfill:

advantages: any one from:
 local treatment so less transport needed [1]
 land can be re-landscaped [1]

disadvantages: any one from:
 wastes land [1]
 polluting released [1]

incineration:

advantages: any one from:
 less waste going to landfill [1]
 heat energy can be harnessed [1]

disadvantages: any one from:
 ash residue is toxic/needs disposal [1]
 polluting gases released [1]

[4]

12. (a) (i) Indicative content:

sugar [1]
 solution/water [1]
 yeast [1]
 no oxygen/anaerobic [1]
 warm conditions [1]
 carbon dioxide [1]

Band	Response	Mark
A	Candidates must use appropriate specialist terms to describe fermentation [5 – 6 indicative content points]. Relevant material is organised with a high degree of clarity and coherence. They must use excellent spelling, punctuation and grammar and the form and style are of a very high standard.	[5]–[6]
B	Candidates must use appropriate specialist terms to describe fermentation [3 – 4 indicative content points]. Relevant material is organised with some clarity and coherence. They use good spelling, punctuation and grammar and the form and style are of a satisfactory standard.	[3]–[4]
C	Candidates describe briefly and partially fermentation [at least 2 indicative content points]. The organisation of material may lack clarity and coherence. They use limited spelling, punctuation and grammar and they have limited use of specialist terms. The form and style are of limited standard	[1]–[2]
D	A response not worthy of credit	[0]

[6]

(ii) $C_2H_4 + H_2O \rightarrow C_2H_5OH$
 correct formulae of reactants [1]
 correct formula of product [1] [2]

(iii) $C_nH_{2n+1}OH$ [1]

(iv) orange to green [1]

(b)

$\begin{array}{c} \text{H} & \text{H} & \text{H} \\ & & \\ \text{H}-\text{C}-\text{C}-\text{C}-\text{OH} \\ & & \\ \text{H} & \text{H} & \text{H} \end{array}$	[1]	$\begin{array}{c} \text{H} & \text{H} & \text{H} \\ & & \\ \text{H}-\text{C}-\text{C}-\text{C}-\text{H} \\ & & \\ \text{H} & \text{OH} & \text{H} \end{array}$	[1]	[4]
propan-1-ol [1]		propan-2-ol [1]		

(c) (i) $2CH_3OH + 3O_2 \rightarrow 2CO_2 + 4H_2O$
 (or $CH_3OH + 1\frac{1}{2}O_2 \rightarrow CO_2 + 2H_2O$)
 correct formulae of reactants [1]
 correct formulae of products [1]
 correct balancing [1] [3]

(ii) limited supply of oxygen [1]

(iii) carbon monoxide [1]
 binds to haemoglobin [1]
 reduces capacity to carry oxygen [1] [3]

13. (a)

Name	Molecular formula	Structural formula	State at room temperature
	C_2H_5COOH		liquid
methanoic acid		$\begin{array}{c} \text{O} \\ \\ \text{H}-\text{C} \\ \\ \text{OH} \end{array}$	liquid
	CH_3COOH	$\begin{array}{c} \text{H} & \text{O} \\ & \\ \text{H}-\text{C}-\text{C} \\ & \\ \text{H} & \text{OH} \end{array}$	liquid
butanoic acid		$\begin{array}{c} \text{H} & \text{H} & \text{H} & \text{O} \\ & & & \\ \text{H}-\text{C}-\text{C}-\text{C}-\text{C} \\ & & & \\ \text{H} & \text{H} & \text{H} & \text{OH} \end{array}$	liquid

[1] per correct row [4]

(b) partially ionised in water [1]

- (c) $2\text{C}_3\text{H}_7\text{COOH} + \text{Mg} \rightarrow (\text{C}_3\text{H}_7\text{COO})_2\text{Mg} + \text{H}_2$
 correct formulae of reactants [1]
 correct formulae of products [1]
 correct balancing [1] [3]
- (d) sodium methanoate [1]
- (e) $2\text{CH}_3\text{COOH} + \text{CaCO}_3 \rightarrow (\text{CH}_3\text{COO})_2\text{Ca} + \text{CO}_2 + \text{H}_2\text{O}$
 correct formulae of reactants [1]
 correct formulae of products [1]
 correct balancing [1] [3]
- (f) (i) $\text{CuCO}_3 + 2\text{C}_3\text{H}_7\text{COOH} \rightarrow (\text{C}_3\text{H}_7\text{COO})_2\text{Cu} + \text{CO}_2 + \text{H}_2\text{O}$
 correct formulae of reactants [1]
 correct formulae of products [1]
 correct balancing [1] [3]
- (ii) limewater [1]
 colourless solution [1] changes to milky [1] [3]
- (iii) green solid disappears [1]
 solution changes from colourless [1] to blue [1] [3]
14. (a) Z [1]
- (b) alkenes [1]
- (c) Y [1]
- (d) X [1]
- (e) (i) hydrogen [1]
- (ii) lit splint [1]
 pop [1] [2]
15. (a) lung damage/global dimming [1]
- (b) incomplete combustion/limited supply of oxygen [1]
- (c) (i) $\text{S} + \text{O}_2 \rightarrow \text{SO}_2$
 correct formulae of reactants [1]
 correct formula of product [1] [2]
- (ii) $\text{SO}_2 + \text{H}_2\text{O} \rightarrow \text{H}_2\text{SO}_3$
 correct formulae of reactants [1]
 correct formula of product [1] [2]
- (iii) damages buildings [1]
 destroys vegetation [1]
 kills fish [1] [3]

2.6 Quantitative Chemistry

Making solutions

1. (a) the glass rod was washed [1]
the rinsings from the beaker and funnel all went into the flask [1] [2]

During the process of making a solution of a solid, it is very important to make sure you do not lose any of the solid or the solution containing the solid and all of it must end up in the volumetric flask. The glass rod is rinsed with deionised water before it is removed from the beaker to remove any solution from it. When the solution is poured through the funnel, the beaker is rinsed and so is the funnel to ensure any solution ends up in the volumetric flask.

- (b) to allow for the volume of washing and rinsings [1]

As deionised water is being used to rinse the glass rod and rinse out the beaker and funnel, the initial volume of deionised water used to dissolve the solid is kept to a minimum so that the final volume is not greater than the volume of the volumetric flask.

- (c) to mix the solution [1]

(d) moles of KOH = $\frac{11.2}{56} = 0.2$ [1]

concentration = $\frac{\text{moles} \times 1000}{\text{volume}} = \frac{0.2 \times 1000}{250} = 0.8$ [1] (mol/dm³) [1]

2. moles of (NH₄)₂SO₄ = $\frac{150 \times 0.12}{1000} = 0.018$ [1]

mass of (NH₄)₂SO₄ = 0.018 × 132 = 2.376 g [1] [2]

3. moles of Mg(NO₃)₂ = $\frac{5.18}{148} = 0.035$ [1]

volume = $\frac{\text{moles} \times 1000}{\text{concentration}} = \frac{0.035 \times 1000}{0.28} = 125 \text{ cm}^3$ [1] [2]

4. (a) limewater [1]

(b) moles of Ca(OH)₂ = $\frac{250 \times 0.0234}{1000} = 0.00585$ [1]

mass of Ca(OH)₂ = 0.00585 × 74 = 0.4329 g [1] [2]

5.

Solute	Mass of solute in the solution (g)	Moles of solute in the solution (mol)	Volume of the solution (cm ³)	Concentration of the solution (mol/dm ³)
NaOH	0.6	0.015	100	0.15
CuCl ₂	32.4	0.24 [1]	250	0.96 [1]
Fe ₂ (SO ₄) ₃	30	0.075 [1]	125 [1]	0.6
Na ₂ CO ₃ ·10H ₂ O	12.87 [1]	0.045 [1]	225	0.2

[6]

To explain the calculations in this table.

- The number of moles is calculated from either mass using $\text{moles} = \text{mass}/M_r$ or from volume and concentration using $\text{moles} = \frac{\text{solution volume} \times \text{concentration}}{1000}$.
- Volume is calculated from moles and concentration using $\text{volume} = \frac{\text{moles} \times 1000}{\text{concentration}}$.
- Concentration is calculated from moles and volume using $\text{concentration} = \frac{\text{moles} \times 1000}{\text{volume}}$.

Acid–base reactions/titrations

6. (a) pipette

[1]

When a volume is quoted to one decimal place such as 25.0 cm³, a measuring cylinder will not measure to that level of accuracy. A pipette (or a burette) should be used.

(b) burette

[1]

(c) pink [1] to colourless [1]

[2]

For all colour changes of an indicator during a titration, think carefully about what is in the conical flask and this is where the indicator is as well. If the alkali is in the conical flask then for phenolphthalein the colour change will be pink to colourless. If you cannot work out what solution is in the conical flask, always guess the colour change as even the wrong way round will get 1 mark.

$$\text{(d) (i) moles of HCl} = \frac{\text{solution volume} \times \text{concentration}}{1000}$$

$$= \frac{17.5 \times 0.03}{1000} = 0.000525 \text{ (} 5.25 \times 10^{-4} \text{)}$$

[1]

$$\text{(ii) moles of NaOH} = 0.000525$$

[1]

$$\text{(iii) concentration of NaOH} = 0.000525 \times 40 = 0.021 \text{ (mol/dm}^3\text{)}$$

[1]

When converting from moles in 25.0 cm³ to concentration in mol/dm³, you multiply by 40. This is the same as dividing by 25 and multiplying by 1000 in the expression $\text{concentration} = \frac{\text{moles} \times 1000}{\text{volume}}$.

7. moles of $\text{Al}(\text{OH})_3 = \frac{6.24}{78} = 0.08$ [1]
 moles of H_2SO_4 required = $\frac{0.08}{2} \times 3 = 0.12$ [1]
 (2:3 ratio of $\text{Al}(\text{OH})_3:\text{H}_2\text{SO}_4$)
 volume of $\text{H}_2\text{SO}_4 = \frac{\text{moles} \times 1000}{\text{concentration}} = \frac{0.12 \times 1000}{1.5} = 80 \text{ cm}^3$ [1] [3]
8. moles of $\text{H}_2\text{SO}_4 = \frac{\text{solution volume} \times \text{concentration}}{1000} = \frac{22.5 \times 0.48}{1000} = 0.0108$ [1]
 moles of $\text{NaOH} = 0.0108 \times 2 = 0.0216$ [1]
 concentration of $\text{NaOH} = \frac{\text{moles} \times 1000}{\text{volume}} = \frac{0.0216 \times 1000}{25.0} = 0.864 \text{ (mol/dm}^3\text{)}$ [1]
9. (a) $0.0085 \times 2 = 0.017$ [1]
 (b) concentration of $\text{KOH} = \frac{\text{moles} \times 1000}{\text{volume}} = \frac{0.017 \times 1000}{25.0} = 0.68 \text{ (mol/dm}^3\text{)}$ [1]
 (c) $0.68 \times 56 = 38.08 = 38.1 \text{ (g/dm}^3\text{)}$ [1]
10. (a) pink [1] to colourless [1] [2]

As the sodium hydroxide solution was in the conical flask, phenolphthalein will be pink initially and as the acid is added it will eventually change to colourless.

(b)

	Initial burette reading (cm ³)	Final burette reading (cm ³)	Titre (cm ³)
Rough titration	0.4	21.5	21.1
First accurate titration	21.5	41.0	19.5
Second accurate titration	22.8	42.3	19.5

[1]

- (c) 19.5 [2] cm³ (correct calculation using rough with units = [1]) [2]

- (d) (i) moles of $\text{NaOH} = \frac{\text{solution volume} \times \text{concentration}}{1000} = \frac{25.0 \times 0.125}{1000} = 0.003125$ [1]

- (ii) 0.003125
 (as 1:1 ratio) [1]

- (iii) concentration = $\frac{0.003125 \times 1000}{19.5} = 0.003125 = 0.16 \text{ (mol/dm}^3\text{)}$ [1]

- (iv) concentration = $0.16 \times 36.5 = 5.84 \text{ (g/dm}^3\text{)}$ [1]

- 11. (a)** to see the colour change more clearly [1]
- (b)** any **two** from:
 swirl the flask [1]
 add dropwise near the end point [1]
 read burette at the bottom of the meniscus [1] [2]

These are the only three answers which are acceptable when describing how to determine the end point accurately.

- (c)** pink [1] to colourless [1] [2]
- (d) (i)** moles of $\text{CH}_3\text{COOH} = \frac{\text{solution volume} \times \text{concentration}}{1000} = \frac{20.0 \times 0.08}{1000} = 0.0016$ [1]
- (ii)** moles of $\text{NaOH} = 0.0016$ (1:1 ratio) [1]
- (iii)** $0.0016 \times 40 = 0.064$ (mol/dm^3) [1]
- (iv)** dilution factor = = 25 [1]

The dilution factor is the final total volume divided by the initial volume of the solution to be diluted. In this case 10.0 cm^3 were diluted to 250 cm^3 so the dilution factor is 25.

- (v)** $0.064 \times 25 = 1.6$ (mol/dm^3) [1]

The dilution factor is used to determine the concentration of the undiluted solution from the concentration of the diluted solution. The diluted solution is 25 times less concentration than the undiluted solution.

- 12. (a)** concentration of $\text{RbOH} = 7.14 \times 10 = 71.4$ (g/dm^3) [1]
- (b)** concentration of $\text{RbOH} = = 0.7$ (mol/dm^3) [1]
- (c) (i)** yellow [1] to red [1] [2]
- (ii)** titrations 2 and 4 [1]
- (iii)** 14.0 [1] cm^3 [1] [2]
- (iv)** moles of $\text{RbOH} = \frac{\text{solution volume} \times \text{concentration}}{1000} = \frac{25.0 \times 0.7}{1000} = 0.0175$ [1]
- moles of $\text{H}_2\text{SO}_4 = \frac{0.0175}{2} = 0.00875$ [1]
- concentration of $\text{H}_2\text{SO}_4 = \frac{\text{moles} \times 1000}{\text{volume}} = \frac{0.00875 \times 1000}{14.0} = 0.625$ (mol/dm^3) [1] [3]
- (v)** concentration of $\text{H}_2\text{SO}_4 = 0.625 \times 98 = 61.25$ (g/dm^3) [1]

13. (a) Indicative content:

- use a safety pipette filler [1]
- rinse pipette with deionised water [1]
- rinse pipette with (barium hydroxide) solution [1]
- draw up the solution until the bottom of the meniscus is on the line [1]
- release into the conical flask [1]
- touch the tip of the pipette onto the surface of the solution [1]

Band	Response	Mark
A	Candidates must use appropriate specialist terms to describe how to prepare and use a pipette [5 – 6 indicative content points]. Relevant material is organised with a high degree of clarity and coherence. They must use excellent spelling, punctuation and grammar and the form and style are of a very high standard.	[5]–[6]
B	Candidates must use appropriate specialist terms to describe how to prepare and use a pipette [3 – 4 indicative content points]. Relevant material is organised with some clarity and coherence. They use good spelling, punctuation and grammar and the form and style are of a satisfactory standard.	[3]–[4]
C	Candidates describe briefly and partially how to prepare and use a pipette [at least 2 indicative content points]. The organisation of material may lack clarity and coherence. They use limited spelling, punctuation and grammar and they have limited use of specialist terms. The form and style are of limited standard	[1]–[2]
D	A response not worthy of credit	[0]

[6]

The pipette and burette should be rinsed with deionised water initially and then with the solution which is going to be used in them.

(b) Relative formula mass (M_r) of $\text{Ba}(\text{OH})_2 \cdot 8\text{H}_2\text{O} = 315$

$$\text{moles of } \text{Ba}(\text{OH})_2 \cdot 8\text{H}_2\text{O} = \frac{9.45}{315} = 0.03 \text{ mol [1]}$$

$$\text{moles of } \text{Ba}(\text{OH})_2 \text{ in } 25.0 \text{ cm}^3 = \frac{25.0 \times 0.03}{1000} = 7.5 \times 10^{-4} \text{ mol [1]}$$

$$\text{moles of HCl required} = 7.5 \times 10^{-4} \times 2 = 0.0015 \text{ mol [1]}$$

$$\text{volume} = \frac{\text{moles} \times 1000}{\text{concentration}} = \frac{0.0015 \times 1000}{0.02} = 75 \text{ [1] cm}^3$$

[4]

Determining formula

- 14. (a)** yellow [1] to red [1] [2]
- (b) (i)** moles of HCl = $\frac{12.5 \times 0.6}{1000} = 0.0075$ [1]
- (ii)** moles of M_2CO_3 in $25.0 \text{ cm}^3 = \frac{0.0075}{2} = 0.00375$ [1]
- (iii)** moles of M_2CO_3 in $100 \text{ cm}^3 = 0.00375 \times 4 = 0.015$ [1]
- (iv)** relative formula mass = $\frac{2.07}{0.015} = 138$ [1]
- (v)** $138 - (12 + 3 \times 16) = 138 - 60 = 78$; relative atomic mass = $\frac{78}{2} = 39$ [1]
M is potassium/K [1] [2]

These calculations are often stepped to take you through each one but they could also be given as a single question where you work through the steps yourself.

- 15. (a)** moles of HCl = $\frac{40.0 \times 0.15}{1000} = 0.006$ [1]
- (b)** moles of Na_2CO_3 in $25.0 \text{ cm}^3 = \frac{0.006}{2} = 0.003$ [1]
- (c)** moles of Na_2CO_3 in $250 \text{ cm}^3 = 0.003 \times 10 = 0.03$ [1]
- (d)** relative formula mass = $\frac{5.34}{0.03} = 178$ [1]
- (e)** $178 - 106 = 72$; $\frac{72}{18} = 4$ [1]

The moles of Na_2CO_3 in the 250 cm^3 of the solution is the same as the moles of the hydrated solid dissolved in the solution. This is important as you use the moles of Na_2CO_3 in 250 cm^3 to work out the relative formula mass of the hydrated substance in (d).

- 16. (a)** all nitrates are soluble [1]
- (b)** $4.0 - 0.8 = 3.2 \text{ g}$ [1]
- (c) (i)** moles of $HNO_3 = \frac{40.0 \times 2}{1000} = 0.08$ [1]
- (ii)** moles of MO = $\frac{0.008}{2} = 0.04$ [1]
- (iii)** relative formula mass = $\frac{3.2}{0.04} = 80$ [1]
- (iv)** $80 - 16 = 64$ [1]
copper/Cu [1] [2]

- 17. (a)** moles of HCl = $\frac{14.0 \times 1.25}{1000} = 0.0175$ [1]
- (b)** moles of Rb_2CO_3 in $25.0 \text{ cm}^3 = \frac{0.0175}{2} = 0.00875$ [1]
- (c)** moles of Rb_2CO_3 in $100 \text{ cm}^3 = 0.00875 \times 4 = 0.035$ [1]
- (d)** mass of Rb_2CO_3 in $100 \text{ cm}^3 = 0.035 \times 230 = 8.05 \text{ g}$ [1]
- (e)** mass of $\text{H}_2\text{O} = 8.68 - 8.05 = 0.63 \text{ g}$ [1]
- (f)** moles of $\text{H}_2\text{O} = \frac{0.63}{18} = 0.035$ [1]
- (g)** 0.035: 0.035 so $x = 1$ [1]

This question is similar to question 15 but the steps are different as this time you determine the mass of the anhydrous salt, then calculate the mass of water of crystallisation by subtraction in (e). Calculating the moles of water and comparing the ratio of this with the moles of the anhydrous gives the degree of hydration in (g).

- 18. (a)** yellow [1] to red [1] [2]
- (b)** rinse burette with deionised water [1]
rinse burette with sulfuric acid [1]
fill burette with sulfuric acid [1]
ensuring the jet is filled/no air bubbles [1] [4]
- (c)** to estimate the end point/allow faster subsequent titrations to be carried out [1]
- (d)** results within 0.2 cm^3 of each other/concordant results [1]
- (e)** any **two** from:
swirl the flask [1]
add dropwise near the end point [1]
read burette at the bottom of the meniscus [1] [2]
- (f)** average titre = $\frac{18.7 + 18.8}{2} = 18.75$ [1] cm^3 [1] [2]
- (g) (i)** moles of H_2SO_4 used = $\frac{18.75 \times 0.40}{1000} = 0.0075$ [1]
- (ii)** moles of $\text{M}(\text{OH})_2$ in $25.0 \text{ cm}^3 = 0.0075$ [1]
- (iii)** moles of $\text{M}(\text{OH})_2$ in $100 \text{ cm}^3 = 0.0075 \times 4 = 0.03$ [1]
- (iv)** relative formula mass of $\text{M}(\text{OH})_2 = \frac{5.13}{0.03} = 171$ [1]
- (v)** relative atomic mass of M = $171 - 34 = 137$ [1]
identity of M = barium/Ba [1] [2]

$$(h) \text{ moles of H}_2\text{SO}_4 \text{ used} = \frac{12.5 \times 0.40}{1000} = 0.005 \text{ [1]}$$

$$\text{moles of M(OH)}_2 \text{ in } 25.0 \text{ cm}^3 = 0.005 \text{ [1]}$$

$$\text{moles of M(OH)}_2 \text{ in } 100 \text{ cm}^3 = 0.005 \times 4 = 0.02 \text{ [1]}$$

$$\text{relative formula mass of M(OH)}_2 = \frac{2.44}{0.02} = 122 \text{ [1]}$$

$$\text{relative atomic mass of M} = 122 - 34 = 88 \text{ [1]}$$

$$\text{identity of M} = \text{strontium/Sr [1]}$$

[6]

Gas volumes and Avogadro's Law

$$19. (a) \text{ moles of Al} = \frac{0.54}{27} = 0.02 \text{ [1]}$$

$$(b) \text{ moles of H}_2 = \frac{0.02}{2} \times 3 = 0.03 \text{ [1]}$$

$$(c) 0.03 \times 24 = 0.72 \text{ dm}^3 \text{ [1]}$$

[1]

[1]

[1]

1 mole of any gas at 20 °C and 1 atm pressure occupies a volume of 24 dm³ which is the same as 24000 cm³. You can convert between moles and gas volume using the expressions:

gas volume (dm³) = moles × 24 or gas volume (cm³) = moles × 24000

$$(d) \text{ moles of HCl} = \frac{0.02}{2} \times 6 = 0.06 \text{ [1]}$$

$$\text{volume of HCl} = \frac{0.06 \times 1000}{2.0} = 30 \text{ cm}^3 \text{ [1]}$$

[2]

$$20. \text{ moles of Ca} = \frac{0.12}{40} = 0.003 \text{ [1]}$$

$$\text{moles of O}_2 = \frac{0.003}{2} = 0.0015 \text{ [1]}$$

$$\text{volume of O}_2 = 0.0015 \times 24000 = 36 \text{ cm}^3 \text{ [1]}$$

[3]

$$21. \text{ moles of Cl}_2 = \frac{0.18}{24} = 0.0075 \text{ [1]}$$

$$\text{moles of Fe} = \frac{0.0075}{3} \times 2 = 0.005 \text{ [1]}$$

$$\text{mass of Fe} = 0.005 \times 56 = 0.28 \text{ g [1]}$$

[3]

$$22. (a) \text{ heat to constant mass}$$

[1]

$$(b) (i) \text{ moles of AgNO}_3 = \frac{7.65}{170} = 0.045 \text{ [1]}$$

[1]

$$(ii) \text{ moles of gas} = \frac{0.045}{2} \times 3 = 0.0675 \text{ [1]}$$

[1]

$$(iii) \text{ volume of gas} = 0.0675 \times 24000 = 1620 \text{ cm}^3 \text{ [1]}$$

[1]

23. (a) gas syringe [1]

$$(b) (i) \text{ moles of CO}_2 = \frac{\text{gas volume}}{\text{molar gas volume}} = \frac{60}{24\,000} = 0.0025 \quad [1]$$

Moles of a gas can be calculated from gas volume by dividing by either 24 if the gas volume is in dm³ or dividing by 24 000 if the gas volume is given in cm³.

$$(ii) \text{ moles of MgCO}_3 = 0.0025 \text{ (1:1 ratio)} \quad [1]$$

$$(iii) \text{ mass of MgCO}_3 = 0.0025 \times 84 = 0.21 \text{ (g)} \quad [1]$$

$$(iv) \text{ mass of H}_2\text{O} = 0.3 - 0.21 = 0.09 \text{ (g)} \quad [1]$$

$$(v) \text{ moles of H}_2\text{O} = \frac{0.09}{18} = 0.005 \quad [1]$$

$$(vi) x = \frac{0.005}{0.0025} = 2 \quad [1]$$

24. (a) equal volumes of gases contain the same number of particles [1]
under the same conditions of temperature and pressure [1] [2]

Learn Avogadro's law. It means that gases will react in volumes which are in the same ratio as the balancing numbers in an equation. So in $2\text{H}_2(\text{g}) + \text{O}_2(\text{g}) \rightarrow 2\text{H}_2\text{O}(\text{l})$, 10 cm³ of hydrogen will react with 5 cm³ of oxygen as the ratio is 2:1. This only applies to gases.

$$(b) \frac{50}{2} = 25 \text{ cm}^3 \quad [1]$$

$$(c) (i) 100 - 25 = 75 \text{ cm}^3 \quad [1]$$

$$(ii) 50 \text{ cm}^3 \quad [1]$$

$$25. (a) \frac{20}{4} \times 3 = 15 \text{ dm}^3 \quad [1]$$

$$(b) (i) \text{ oxygen used} = \frac{150}{4} \times 3 = 112.5 \text{ [1] cm}^3$$

$$\text{oxygen remaining} = 150 - 112.5 = 37.5 \text{ [1] cm}^3 \quad [2]$$

$$(ii) \frac{150}{2} = 75 \text{ cm}^3 \quad [1]$$

$$(iii) 37.5 + 75 = 112.5 \text{ cm}^3 \quad [1]$$

In part (b), there was an excess of oxygen as 150 cm³ of ammonia only reacts with 112.5 cm³ of oxygen. The ammonia is therefore the limiting reactant and its moles determine the moles of nitrogen formed.

Atom Economy

26. (a) (i) atom economy = $\frac{\text{mass of desired product}}{\text{total mass of products}} \times 100$ [1]

(ii) atom economy = $\frac{64}{216} \times 100 = 29.6\%$ [1] [2]

(b) atom economy = $\frac{128}{192} \times 100 = 66.7\%$ [1] [2]

(c) from its ore as higher atom economy means less waste [1]

27. (a) Reaction C [1]

(b) atom economy = $\frac{92 [1]}{180 [1]} \times 100 = 51.1\%$ [1] [3]

(c) fermentation [1]

2.7 Electrochemistry

1. (a) decomposition (of a liquid electrolyte) [1]
using (a direct current of) electricity [1] [2]
- (b) cathode [1]
- (c) ions can move [1] and carry charge [1] [2]

A very common **incorrect** answer in (c) would be "delocalised electrons can move and carry charge".

- (d) electrolyte [1]
- (e) yellow–green or green [1] gas [1] [2]
- (f) $\text{Li}^+ + \text{e}^- \rightarrow \text{Li}$
Li⁺ on left of arrow and Li on right [1]
+e⁻ on left [1] [2]
2. (a) metal: delocalised electrons [1] can move and carry charge [1]
molten ionic compounds: ions can move [1] and carry charge [1]
molten ionic compounds undergo decomposition [1] [5]
- (b) red–brown [1] gas [1] [2]
- (c) hydrogen [1] [1]
- (d) $\text{Pb}^{2+} + 2\text{e}^- \rightarrow \text{Pb}$
Pb²⁺ on left of arrow and Pb on right [1]
+ e⁻ on left [1]
correct balancing [1] [3]
- (e) purple [1] gas [1] [2]

In (e) iodine is produced at the anode and as the mixture is being heated, the iodine sublimates and is produced as a gas.

3.

Electrolyte	Product formed at the anode	Product formed at the cathode	Half equation for reaction at anode	Half equation for reaction at cathode
Molten zinc chloride	chlorine [1]	zinc	$2\text{Cl}^- \rightarrow \text{Cl}_2 + 2\text{e}^-$ [3]	$\text{Zn}^{2+} + 2\text{e}^- \rightarrow \text{Zn}$ [3]
Dilute sulfuric acid	oxygen and water	hydrogen [1]	$4\text{OH}^- \rightarrow \text{O}_2 + 2\text{H}_2\text{O} + 4\text{e}^-$ [3]	$2\text{H}^+ + 2\text{e}^- \rightarrow \text{H}_2$ [3]
Molten sodium oxide	oxygen [1]	sodium [1]	$2\text{O}^{2-} \rightarrow \text{O}_2 + 4\text{e}^-$ [3]	$\text{Na}^+ + \text{e}^- \rightarrow \text{Na}$ [2]
Molten lithium bromide	bromine [1]	lithium [1]	$2\text{Br}^- \rightarrow \text{Br}_2 + 2\text{e}^-$ [3]	$\text{Li}^+ + \text{e}^- \rightarrow \text{Li}$ [2]

The half equations are marked as:
 ion on left of arrow and product on right [1]
 e^- correctly placed with + (or -) [1]
 correct balancing [1]

4. (a) hydrogen ions gain electrons [1]
 gain of electrons is reduction [1] [2]
- (b) platinum [1]
- (c) bubbles of a colourless [1] gas [1] [2]
- (d) $4\text{OH}^- \rightarrow \text{O}_2 + 2\text{H}_2\text{O} + 4\text{e}^-$
 OH^- on left of arrow and O_2 and H_2O on right [1]
 $+ \text{e}^-$ on right (or $- \text{e}^-$ on left) [1]
 correct balancing [1] [3]
- (e) 20 cm^3 [1]

The volume of gas produced at the anode is half the volume of gas produced at the cathode.

5. (a) bauxite [1]
- (b) lower operating temperature [1]
 increase conductivity [1] [2]
- (c) to retain the heat [1]
- (d) $900 - 1000 \text{ }^\circ\text{C}$ [1]
- (e) A = (graphite) anode [1]
 B = (graphite) cathode [1] [2]

- (f) $\text{Al}^{3+} + 3\text{e}^- \rightarrow \text{Al}$
 Al^{3+} on left of arrow and Al on right [1]
 $+ \text{e}^-$ on left [1]
 correct balancing [1] [3]
- (g) $2\text{O}^{2-} \rightarrow \text{O}_2 + 4\text{e}^-$
 O^{2-} on left of arrow and O_2 on right [1]
 $+ \text{e}^-$ on right (or $- \text{e}^-$ on left) [1]
 correct balancing [1] [3]
- (h) carbon anode wears away [1]
 $\text{C} + \text{O}_2 \rightarrow \text{CO}_2$
 correct formula of reactants [1]
 correct formula of product [1] [3]
6. (a) inert/unreactive [1]
 good conductor of electricity [1] [2]
- (b) yellow-green or green [1] gas [1] [2]
- (c) ions can move [1] and carry charge [1] [2]
- (d) $\text{K}^+ + \text{e}^- \rightarrow \text{K}$
 K^+ on left of arrow and K on right [1]
 $+ \text{e}^-$ on left [1] [2]
- (e) moles of KCl = 0.14 [1]
 moles of Cl_2 = 0.07 [1]
 volume of Cl_2 = $0.07 \times 24000 = 1680 \text{ cm}^3$ [1] [3]
7. (a) positive electrode = anode and negative electrode = cathode [1]
- (b) $2\text{H}^+ + 2\text{e}^- \rightarrow \text{H}_2$
 H^+ on left of arrow and H_2 on right [1]
 $+ \text{e}^-$ on left [1]
 correct balancing [1] [3]
- (c) $4\text{OH}^- \rightarrow \text{O}_2 + 2\text{H}_2\text{O} + 4\text{e}^-$
 OH^- on left of arrow and O_2 and H_2O on right [1]
 $+ \text{e}^-$ on right (or $- \text{e}^-$ on left) [1]
 correct balancing [1] [3]
- (d) 4e^- produces 2 H_2 [1]
 and 1 O_2 [1] [2]
- (e) platinum [1]
- (f) lit splint [1]
 pop [1] [2]
- (g) relights [1]

8. (a) bauxite [1]

(b) $2\text{Al}_2\text{O}_3 \rightarrow 4\text{Al} + 3\text{O}_2$
 correct formula of reactant [1]
 correct formula of products [1]
 correct balancing [1] [3]

(c) cryolite [1]

(d) (i)

Electrode	Electrolysis product	Half equation
Anode	oxygen [1]	$2\text{O}^{2-} \rightarrow \text{O}_2 + 4\text{e}^-$ O^{2-} on left of arrow and O_2 on right [1] $+ \text{e}^-$ on right (or $- \text{e}^-$ on left) [1] correct balancing [1] [3]
Cathode	aluminium [1]	$\text{Al}^{3+} + 3\text{e}^- \rightarrow \text{Al}$ Al^{3+} on left of arrow and Al on right [1] $+ \text{e}^-$ on left [1] correct balancing [1] [3]

(ii) oxide ions lose electrons [1]
 loss of electrons is oxidation [1] [2]

(e) carbon/graphite anode [1] reacts with oxygen [1] [2]

(f) substantially less energy needed to recycle/saves waste [1]

2.8 Energy Changes in Chemistry

1. (a) purple [1]

(b) the energy required to break the bonds in HI [1]
is more [1] than
the energy released when bonds form in H₂ and I₂ [1] [3]

This is a common question and be careful that you do not lose marks by contradicting yourself. Many will state that energy is required to form bonds which means you could lose 2 out of the 3 marks as the comparison mark and the third mark will not be awarded.

2. (a)

Reaction	Equation	Energy change (kJ)	Endothermic	Exothermic
A	$\text{C}_2\text{H}_5\text{OH} + 3\text{O}_2 \rightarrow 2\text{CO}_2 + 3\text{H}_2\text{O}$	-1368		✓
B	$\text{CaCO}_3 \rightarrow \text{CaO} + \text{CO}_2$	+178	✓ [1]	
C	$\text{NaOH} + \text{HCl} \rightarrow \text{NaCl} + \text{H}_2\text{O}$	-57		✓ [1]
D	$\text{Zn} + \text{CuSO}_4 \rightarrow \text{ZnSO}_4 + \text{Cu}$	-217		✓ [1]

(b) A = combustion [1]
B = thermal decomposition [1]
C = neutralisation [1]
D = displacement/redox [1] [4]

(c) gives out heat [1]

(d) the energy required to break the bonds in C₂H₅OH and O₂ [1]
is less [1] than
the energy released when bonds form in CO₂ and H₂O [1] [3]

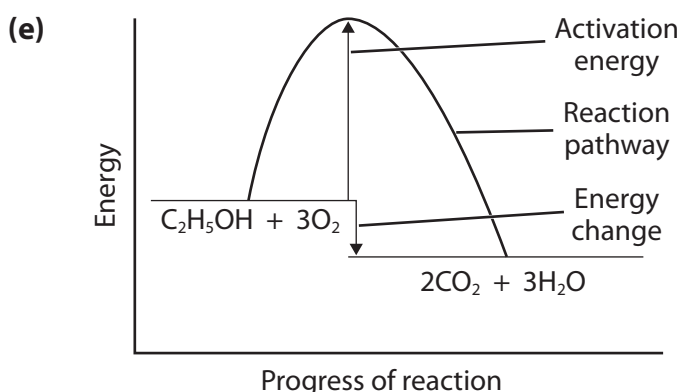

products labelled as 2CO₂ + 3H₂O and at lower level than reactants [1]
reaction pathway drawn and labelled [1]
activation energy [1]
energy change [1] [4]

3. (a) one C=C [1]
four C—H [1] [2]
- (b) $611 + 4(412) + 3(496) = 3747$ kJ [1]
- (c) $4(803) + 4(463) = 5064$ kJ [1]
- (d) $3747 - 5064 = - [1] 1317 [1]$ kJ [2]

The energy change in a reaction is the energy required to break the bonds in the reactants minus the energy formed when bonds are formed in the products. It is important to include the sign, so either + or – is needed for an energy change. Exothermic reactions have a negative energy change and endothermic reactions have a positive energy change.

- (e) exothermic as energy change is negative [1]
4. (a) energy required to break bonds = $4(412) + 4(463) = 3500$ kJ [1]
energy produced when bonds form = $2(803) + 4(436) = 3350$ kJ [1]
energy change = $3500 - 3350 = + [1] 150 [1]$ kJ [4]
- (b) endothermic as energy change is positive [1]
5. (a) $-484 = 2(436) + \text{O}=\text{O} [1] - 4(463) [1]$
 $\text{O}=\text{O} = 496$ kJ [1] [3]
- (b) the energy required to break the bonds in H_2 and O_2 [1]
is less [1] than
the energy released when bonds form in H_2O [1] [3]
6. (a) endothermic as energy change is positive/products higher energy level than reactants [1]

(b)

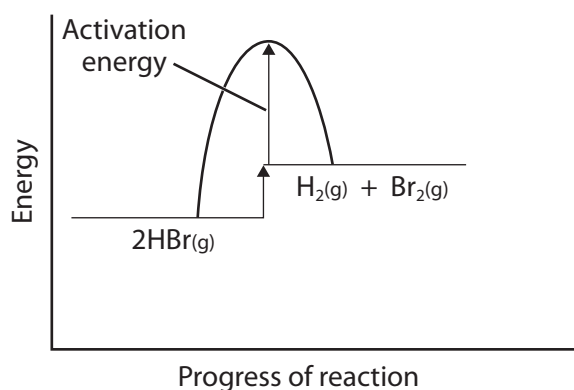

label for activation energy from HBr level to top of pathway [1]

- (c) minimum energy required for a reaction to occur [1]
- (d) $2\text{HBr}(\text{g}) \rightarrow \text{H}_2(\text{g}) + \text{Br}_2(\text{g})$ [1]

- (e) energy required to break bonds = $2(362) = 724$ kJ [1]
 energy produced when bonds form = $436 + 190 = 626$ kJ [1]
 energy change = $724 - 626 = + [1] 98 [1]$ kJ [4]

7. (a) energy required to break bonds = $163 + 4(386) + 496 = 2203$ kJ [1]
 energy produced when bonds form = $916 + 4(463) = 2768$ kJ [1]
 energy change = $2203 - 2768 = - [1] 565 [1]$ kJ [4]

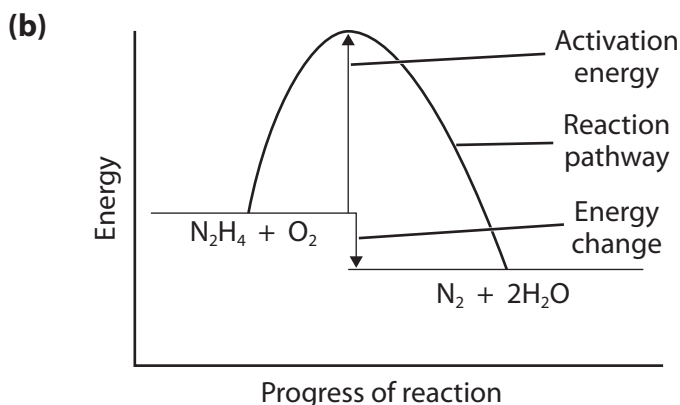

- products labelled as $N_2 + 2H_2O$ and at lower level than reactants [1]
 reaction pathway drawn and labelled [1]
 activation energy [1]
 energy change [1] [4]

- (c) (i) the energy required to break the bonds in N_2H_4 [1]
 is less [1] than
 the energy released when bonds form in N_2 and H_2 [1] [3]

- (ii) $-81 = 163 + 4(386) [1] - (916 + 2(H-H)) [1]$
 $2(H-H) = 872 [1]$
 $H-H = 436$ kJ [1] [4]

- (iii) substance which increases the rate of a chemical reaction [1]
 without being used up [1] [2]

- (iv) provides an alternative reaction pathway [1]
 of lower activation energy [1] [2]

8. (a) C [1]

- (b) D [1]

- (c) A [1]

- (d) iron [1]

- (e) (i) energy required to break bonds = $916 + 3(436) = 2224$ kJ [1]
 energy produced when bonds form = $6(386) = 2316$ kJ [1]
 energy change = $2224 - 2316 = - [1] 92 [1]$ kJ [4]

- (ii) exothermic as energy change is negative [1]

2.9 Gas Chemistry

1. (a) chlorine [1]
 (b) carbon dioxide [1]
 (c) hydrogen [1]

Hydrogen is described as a clean fuel as the only product of combustion is water which is non-polluting.

- (d) ammonia [1]
 (e) ethene [1]
 (f) oxygen [1]
 (g) carbon dioxide and chlorine and oxygen and xenon [1]

2. (a) strong triple covalent bond [1]
 requires substantial energy to break [1] [2]

- (b) coolant [1]

(c)

Gas	Percentage composition (%)
nitrogen	78 [1]
oxygen [1]	21
carbon dioxide [1]	0.037
argon	approx 1 [1]

[4]

- (d) any **two** from:
 colourless
 odourless
 insoluble in water [3]

When answering a question on physical properties, do not give chemical properties. A common incorrect answer here would be unreactive, but this is a chemical property.

- (e) (i) oxygen/O₂ [1]

- (ii) carbon dioxide/CO₂ [1]

- (iii) any **one** from:
 water vapour
 helium
 neon
 argon
 krypton
 xenon
 radon [1]

(f) (i) glass rod [1]
dipped in concentrated hydrochloric acid [1]
white smoke/fumes/solid observed [1] [3]

(ii) $\text{N}_2 + 3\text{H}_2 \rightarrow 2\text{NH}_3$
correct formulae of reactants [1]
correct formula of product [1]
correct balancing [1] [3]

(iii) manufacture of fertilisers [1]

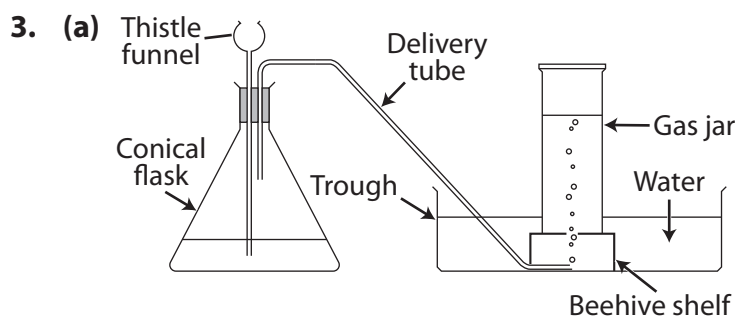

[1] per label [6]

(b)

Gas	Solid	Solution
oxygen [1]	manganese(IV) oxide	hydrogen peroxide [1]
hydrogen	zinc/magnesium [1]	hydrochloric acid [1]
carbon dioxide [1]	calcium carbonate	hydrochloric acid

[5]

(c) any **one** from:
in weather balloons
rocket fuel
as a clean fuel [1]

(d) prevent gas escaping through the funnel [1]

4. (a) sulfur dioxide [1]

(b) yellow [1] solid [1] [1]

(c) blue flame [1]
sulfur melts to form a red liquid [1] [2]

(d) colourless/misty [1] gas [1] [2]

(e) sulfur gains oxygen [1]
gain of oxygen is oxidation [1] [2]

(f) moles of sulfur = $\frac{1.44}{32} = 0.045$ [1]

moles of $\text{SO}_2 = 0.045$ [1]

volume of $\text{SO}_2 = 0.045 \times 24000 = 1080 \text{ cm}^3$ [1]

[3]

(g) (i) moles of $\text{SO}_2 = \frac{45}{24000} = 0.001875$ [1]

[1]

(ii) moles of $\text{KOH} = 2 \times 0.001875 = 0.00375$ [1]

[1]

(iii) volume of KOH solution = $\frac{0.00375 \times 1000}{0.15} = 25 \text{ cm}^3$ [1]

[1]

5. (a)

Oxide	Basic	Acidic
copper(II) oxide	✓	
sulfur dioxide		✓ [1]
magnesium oxide	✓ [1]	
carbon dioxide		✓ [1]

[3]

Oxides of metals are generally basic and oxides of non-metals are generally acidic. There are some neutral oxides of non-metals such as carbon monoxide and water.

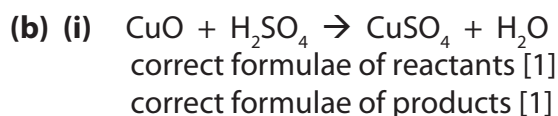

[2]

(ii) colourless [1] to blue [1]

[2]

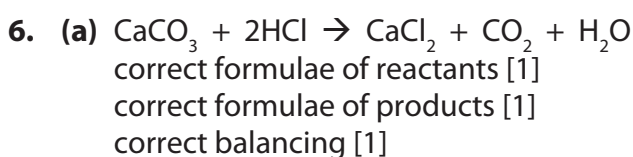

[3]

9. (a)

Element	Name of the oxide	Formula of oxide
carbon	carbon dioxide [1]	CO ₂
magnesium	magnesium oxide	MgO [1]
copper	copper(II) oxide [1]	CuO

[3]

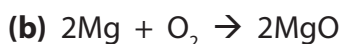

correct formulae of reactants [1]

correct formula of product [1]

correct balancing [1]

[3]

(c) grey solid [1]

burns with a bright white light [1]

white solid formed [1]

[3]

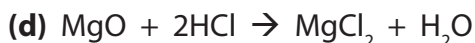

correct formulae of reactants [1]

correct formulae of products [1]

correct balancing [1]

[3]

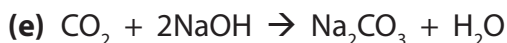

correct formulae of reactants [1]

correct formulae of products [1]

correct balancing [1]

[3]

(f) CO₂ = acidic

magnesium oxide = basic

CuO = basic

[1]

(g) carbonic acid

[1]

10. (a) magnesium is more reactive [1] than zinc [1]

[1]

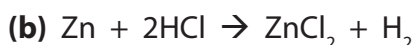

correct formulae of reactants [1]

correct formulae of products [1]

correct balancing [1]

[3]

(c) only product of combustion is water [1]

water is non-polluting [1]

[2]

(d) any **two** from:

colourless

odourless

insoluble in water

less dense than air

[2]

As mentioned before do not give chemical properties when asked for physical properties. Flammable is a common answer here but hydrogen burning is a chemical reaction so this is not accepted.

- (e) lit splint [1]
pop [1] [2]
11. (a) $\text{CO}_2 + \text{H}_2\text{O} \rightarrow \text{H}_2\text{CO}_3$
correct formulae of reactants [1]
correct formula of product [1]
carbonic acid [1] [3]
- (b) calcium hydroxide solution [1]
- (c) colourless solution [1]
change to milky [1]
back to colourless with excess CO_2 [1] [3]
- (d) sodium carbonate [1]
water [1] [2]
- (e) (i) sulfur dioxide [1]
(ii) 3 – 6 [1]

Carbonic acid is a weak acid so any value in the range 3 – 6 is acceptable.